



COMMONWEALTH OF PENNSYLVANIA
DEPARTMENT OF GENERAL SERVICES
HARRISBURG

Thank you for responding to the Commonwealth of Pennsylvania's Solicitation for Proposal (SFP) #94688 to lease to the Commonwealth 15,440 usable square feet of office space in York County, Pennsylvania. The space will be occupied by the Pennsylvania State Police.

The availability of private and/or public parking should be included in proposals.

Enclosed you will find SFP #94688 which includes 5 appendices, including a sample draft lease.

This SFP contains information that will guide you in preparing a proposal submission on the enclosed forms. **To be considered, all proposals must be submitted utilizing the enclosed forms.** Proposals must be addressed to the Bureau of Real Estate, Room 503, North Office Building, Harrisburg, Pennsylvania 17125 and received by the Commonwealth of Pennsylvania by 3:00 P.M., Friday, April 10, 2015. **PROPOSALS WILL NOT BE ACCEPTED AFTER THIS TIME.**

PLEASE NOTE THAT SFPs ARE NOT PUBLIC BID OPENINGS.

Your proposal must be submitted in a sealed envelope. THE ENVELOPE MUST BE MARKED WITH SFP #94688, AGENCY'S NAME, REAL ESTATE COORDINATOR'S NAME, SQUARE FOOTAGE, AND DUE DATE. THIS INFORMATION MUST ALSO BE SHOWN ON THE OUTSIDE OF ANY COURIER OR MAILING ENVELOPE. Do not submit a proposal for another SFP in the same envelope with your proposal for this particular SFP. Please be advised that this is a proposal solicitation process. The Commonwealth of Pennsylvania reserves the right to reject any or all offers, waive any defect or negotiate for better terms.

This solicitation reflects material changes which have been made to the Commonwealth lease solicitation process. Payment of prevailing wages is now a requirement of the Commonwealth's leasing program when a proposer offers to construct a new facility or substantially rehabilitate an existing facility. Specific information on the payment of prevailing wages requirement can be found on Page 5 of this SFP. There are also new requirements concerning the Right to Know Law. Specific information on the disclosure of proposal contents can be found on Page 8 of this SFP.

You should address the availability of private and/or public parking in your proposal.

Please be sure to carefully read the whole document. If you have any questions concerning the attached information, please contact David Weyandt directly at (717) 525-5255 or daweyandt@pa.gov.

**503 North Office Building, Harrisburg, PA 17125
Telephone: 717-787-4394 FAX No: 717-783-0570**

SOLICITATION FOR PROPOSAL (SFP) # 94688

Pennsylvania State Police

Date of Issue:
February 12, 2015

Issuing Office:
Department of General Services
Bureau of Real Estate
Room 503 North Office Building
Harrisburg, Pennsylvania 17125
(717) 787-4394

Table of Contents

	<u>Pages</u>
I. General Information for the Proposer	4-9
II. Proposal Requirements	10-11
Appendix A	Lease Standard Terms and Conditions (Attachment A of New Lease)
Appendix B	Required Documents
Appendix C	Building Specifications (Attachment B and Attachment C of New Lease)
Appendix D	Commonwealth Requirements
Appendix E	Geographic Boundaries

I. GENERAL INFORMATION FOR THE PROPOSER

PURPOSE

The purpose of this Solicitation for Proposal (SFP) is to obtain proposals to provide 15,440 net usable square feet of office space, to house approximately 84 Commonwealth employees. The space must be located within the following boundaries: within a three (3) mile radius of the intersection of Leader Heights Road (SR 182) and Joppa Road or the intersection of Kreider Road and North Street (Lake Road) near York, PA. Proposals which offer space outside of these boundaries cannot be considered for award of the lease.

Proposers should prepare and submit proposals to be considered by the Commonwealth of Pennsylvania (Commonwealth) for a fifteen (15) year lease (with options for two (2) – five (5) year renewal terms) to be occupied by the Pennsylvania State Police.

Proposers are invited to submit proposals based on one or both of the following options:

- Option 1 - Lessor will provide a full service lease in accordance with the Proposal Requirements on Page 10 of this SFP.
- Option 2 – Lessee will provide janitorial services and supplies, trash removal, snow and ice removal, and lawn and shrub care. Lessor provides all other services in accordance with the Proposal Requirements on Page 10 of this SFP.

The availability of private and/or public parking should be included in proposals.

ISSUING OFFICE

The Department of General Services (DGS), Bureau of Real Estate, issues this SFP for the Commonwealth. The point of contact is:

Mr. David Weyandt
Department of General Services
Bureau of Real Estate
Room 503 North Office Building
Harrisburg, PA 17125
(717) 525-5255 or daweyandt@pa.gov

Only the DGS Bureau of Real Estate is authorized to negotiate the terms and conditions of a proposed lease agreement. No understanding shall be binding upon the Commonwealth until all of the following occur: (1) the parties' understanding has been reduced to a formal written lease agreement; (2) the lease agreement has received all necessary Commonwealth approvals, including, but not limited to, the approval of the Board of Commissioners of Public Grounds and Buildings; (3) the lease agreement has been signed by the Secretary of the Department of General Services, and (4) the fully executed lease agreement has been delivered by DGS to the selected proposer.

SCOPE

This SFP contains instructions governing the proposals to be submitted and the material to be included therein; a description of the services to be provided; requirements that must be met to be eligible for consideration; and other requirements to be met by each interested party.

RESPONSE DATE

To be considered, proposals must arrive at the issuing office, on or before the date and time specified in the cover letter. Proposals must be returned in the envelope provided with the proposal packet. **ALL LATE PROPOSALS SHALL BE REJECTED.**

NOTICE TO PROPOSERS OF PREVAILING WAGE REQUIREMENTS

To the extent that a proposer offers to construct a new facility, to substantially rehabilitate an existing facility, or to substantially alter an existing facility in accordance with Commonwealth agency specifications/drawings, and the construction/substantial rehabilitation/substantial alterations will have a total estimated cost that exceeds \$25,000, the following prevailing wage requirements shall be included in the lease. "Substantial rehabilitation" is the conversion or adaptation of an existing facility into a safe, structurally sound building, by gutting and extensive re-construction, to make the building suitable for use by the Commonwealth agency. As a guideline, if the building foundations, building shell (outer walls, interior support walls or roof) or major building systems (HVAC, plumbing, electrical) are substantially altered or replaced, it is substantial rehabilitation. "Substantial alterations" are those alterations to an existing facility by the lessor in accordance with Commonwealth agency specifications/plans/drawings where final plans, drawings and specifications must be reviewed and approved by the Commonwealth agency. These terms do not include cosmetic improvements, routine maintenance, minor non-structural alterations and upgrades.

The lease shall require the lessor and lessor's contractor(s) to pay no less than the wage rates as issued by the Secretary of the Pennsylvania Department of Labor and Industry for each craft or classification of all workers needed to perform the contract(s) for the construction/substantial rehabilitation/substantial alterations of the facility. The construction/substantial rehabilitation/substantial alterations required by the lease will be subject to the provisions, conditions, duties, requirements, remedies and penalties of the Pennsylvania Prevailing Wage Act, 43 P.S. § 165-1 *et seq.* The prevailing minimum wage predetermination, as issued by the Secretary of Labor and Industry, shall be attached to the lease and made a part of the lease. No workers may be employed in the construction/substantial rehabilitation/substantial alterations, except in accordance with the classifications in the prevailing minimum wage predetermination of the Secretary of Labor and Industry. If additional or different classifications are necessary, the lessor shall request the Department of General Services to petition the Secretary of Labor and Industry for rates for additional or different classifications.

The rent requested by proposers offering to construct a new facility or to substantially rehabilitate an existing facility or to make substantial alterations must take into consideration the requirement of the lessor and lessor's contractor(s) to pay no less than the prevailing wage rates issued by the Secretary of Labor and Industry.

In order to view the current prevailing wages for each craft or classification of workers needed to perform the contract(s) for the construction/substantial rehabilitation/substantial alterations of the leased facility for the locality where the facility will be constructed/substantially rehabilitated go to http://www.dli.state.pa.us/landi/li_apps/requestPW.asp and request the prevailing wages. These are the applicable wage rates **provided** a lease is negotiated and fully executed within 120 days of the proposal response date. In the event the lease is not fully executed within this 120 day period, it will be necessary to request and obtain new, current prevailing minimum wage rates from the Secretary of Labor and Industry that the lessor or lessor's contractors must pay to those employees involved in the construction/improvement/alteration of the leased facility.

Proposals must include a statement indicating whether or not the rent is based upon the requirement to pay prevailing wages.

If, after receipt of proposals, the DGS determines that the lessor and lessor's contractor(s) should pay the prevailing minimum wage rates when the lessor's proposal did not include consideration of this requirement, DGS may give the proposer the opportunity to revise its offered rental amounts to include allowance for payment of prevailing wages. When such a determination is made, the lease shall require, or be amended to require, the lessor and lessor's contractor(s) to pay the prevailing minimum wage rates as issued by the Secretary of the Pennsylvania Department of Labor and Industry. If this occurs, the lessor and DGS shall negotiate either an increase in the rental rate or the amount of a one-time payment to cover the increase in cost as a result of including this requirement. The lease will be subject to the provisions, conditions, duties, requirements, remedies and penalties of the Pennsylvania Prevailing Wage Act, 43 P.S. § 165-1 *et seq.*

SUBMISSION OF PROPOSALS

To be considered, interested parties must submit a complete response to this SFP, using the format provided in the "Proposal Requirement" section of this document. An interested party will make no other distribution of the proposal. An official who is authorized to bind the interested party to its provisions must sign the proposal. For this SFP, the conditions of the proposal must remain valid for at least sixty (60) days from the date specified in the cover letter. **Moreover, the conditions of the selected proposal will become contractual obligations if a contract is entered into with the Commonwealth.**

A complete proposal package is necessary for evaluation of your proposal. Failure to include any of the required information or forms will delay evaluation of your proposal and may, at the Commonwealth's sole discretion, result in the rejection of your proposal.

The Commonwealth now allows alternate responses for one solicitation. In order to be considered as a complying submission, a proposal must initially adhere strictly to the solicitation specifications in all material regards. However, in addition to this component, a proposer may, at the proposer's discretion, submit one or more alternate proposals that vary from the specifications. In particular, the proposer may, by way of example, propose alternate finishes or spatial layouts that allow the proposer to submit a more competitive price proposal. The proposal must clearly label the primary proposal, and all alternates, and a clear breakdown of the price differentials should be delineated. DGS will consider and evaluate the primary and all alternate proposals at its sole discretion.

TYPE OF AGREEMENT

The selected party will be expected to enter into a lease agreement in substantially the same form as the sample lease which is attached as **APPENDIX A** of this SFP. **The terms and conditions of this SFP and the selected party's proposal will be incorporated into the lease by reference.**

REJECTION OF PROPOSALS

The Commonwealth reserves the right to reject any and/or all proposals received as a result of this request, or to negotiate separately with competing contractors. If, in the opinion of the Commonwealth, contract negotiations with the selected party cannot be concluded **within 60 days following the selected party's receipt of a draft lease agreement**, the Commonwealth may at its sole discretion, immediately discontinue negotiations with the selected party and commence negotiations with any other interested party.

INCURRING COSTS

The Commonwealth is not liable for any costs incurred by interested parties related to the preparation of their proposals for this SFP.

ECONOMY OF PREPARATION

Proposals should be prepared simply and economically, providing a straightforward, concise description of the interested party's ability to meet the requirements of the SFP.

ORAL PRESENTATION

An interested party that submits a proposal may be required to make an oral presentation of its development plan to DGS.

AMENDMENT TO THE SFP

If it becomes necessary to revise any part of this SFP, an amendment will be issued to all interested parties who received the original SFP. **For any interested party who downloads the SFP from the DGS website, it will be that party's responsibility to check the website for amendments to the SFP prior to the submission of its proposal.**

SELECTED PARTY RESPONSIBILITIES

The selected party will be required to assume responsibility for all services offered in the proposal whether or not the selected party actually performs them. Further, the Commonwealth will consider the selected party to be the sole point of contact with regard to contractual matters.

DISCLOSURE OF PROPOSAL CONTENTS

- **Confidential Information.** The Commonwealth is not requesting, and does not require, confidential proprietary information or trade secrets to be included as part of proposers' submissions in order to evaluate proposals submitted in response to this SFP. Accordingly, except as provided herein, proposers should not label proposal submissions as confidential or proprietary or trade secret protected. Any proposer who determines that it must divulge such information as part of its proposal must submit the signed written statement described in subsection c.(2) below and must additionally provide a redacted version of its proposal, which removes only the confidential proprietary information and trade secrets, for required public disclosure purposes.
- **Commonwealth Use.** All material submitted with the proposal shall be considered the property of the Commonwealth of Pennsylvania and may be returned only at the issuing office's option. The Commonwealth has the right to use any or all ideas not protected by intellectual property rights that are presented in any proposal regardless of whether the proposal becomes part of a lease. Notwithstanding any proposer copyright designations contained on proposals, the Commonwealth shall have the right to make copies and distribute proposals internally and to comply with public record or other disclosure requirements under the provisions of any Commonwealth or United States statute or regulation, or rule or order of any court of competent jurisdiction.
- **Public Disclosure.** Public records requests for proposals are governed by and shall be handled in the following manner:

After the award of a lease pursuant to this SFP, all proposal submissions are subject to disclosure in response to a request for public records made under the Pennsylvania Right-to-Know-Law, 65 P.S. § 67.101, et seq., commencing January 1, 2009. If a proposal submission contains confidential proprietary information or trade secrets, a signed written statement to this effect must be provided with the submission in accordance with 65 P.S. § 67.707(b) for the information to be considered exempt from disclosure under 65 P.S. § 67.708(b)(11).

NEWS RELEASES

News releases pertaining to this project will be made in coordination with the issuing office, and subject to Commonwealth approval.

FACILITY ACCESS

Consistent with safety and operational factors, the selected proposer will provide the Commonwealth unlimited access to the leased premises during the construction period.

PENNSYLVANIA STATE SALES AND USE TAX

The proposed facility is subject to all applicable Pennsylvania Sales and Use Tax legislation. There is no special tax exemption for this project.

ORDER OF PRECEDENCE

If any discrepancies in interpretation arise, the terms of the Lease Agreement are the first point of reference, the SFP and all attachments are the second, and the Proposal is the third.

II. PROPOSAL REQUIREMENTS

INTRODUCTION

This section contains instructions governing the proposals to be submitted and the material to be included in the proposal. The proposal shall be submitted in the format delineated below.

It is the obligation of the proposer to become fully cognizant of all factors relevant to the site including, but not limited to, existing and surrounding zoning and zoning requirements, physical characteristics and conditions of the site and improvements, asbestos and environmental hazards, adequacy of public facilities, utility services, legal restrictions, and all other information relating to legal requirements, land-use planning, or design requirements and restraints.

REQUIRED DOCUMENTS

The following required documents **must** be completed accurately and submitted as part of your proposal (**APPENDIX B**):

1. GSRE -19 Proposal to Lease Space to the Commonwealth

As indicated on GSRE – 19, certain required services are requested by the agency in this SFP and should be included as part of your proposal. These required services may consist of, but are not limited to the following:

- a. All Utilities
- b. Janitorial Services and Supplies (please check the janitorial schedule included in the Agency Specifications attached to this SFP.)
- c. Trash Removal
- d. Snow and Ice Removal
- e. Sewer and Water
- f. Lawn and Shrub Care
- g. Acquisition of the Site
- h. Permitting
- i. All Professional Fees
- j. Financing
- k. Building Construction
- l. Real Estate Taxes
- m. Insurance

2. GSRE - 6 Lessor Identity Disclosure

3. GSRE - 47 Agency Agreement/Limited Agent Authority

4. GSRE - 42M Contractor Responsibility Certification

5. GSRE - 54 Notice - Bureau of Real Estate is Sole Agent for Commonwealth

6. GSRE – 63 Acknowledgment/Usable Area Definition

7. GSRE – 64 Consent to Release or Obtain Information and Contact Professional References

8. Prevailing Wage Pre-determination issued by the Department of Labor & Industry (page 6 of this SFP)

In addition to the required standard forms, a graphic schedule and narrative on the schedule through the design and construction phases of the project is required. This schedule will be used to complete **Paragraph 18** of the draft lease agreement (APPENDIX A), and will include how the proposer plans to meet its proposed final completion date. The schedule for the development of the site should include but are not limited to:

- Test Fit
- Site Control
- Code and Building Permit Approvals
- Construction
- Utility Disconnect/Reconnect

ADDITIONAL INFORMATION

In order to assist with the evaluation of your proposal, the following should be included with your proposal package:

- Drawings - Site Plan(s), Floor Plans, Elevations and Building Sections.
- Photographs - Please mark photographs for easy reference .
- Any documentation the proposer determines to be necessary to explain the proposal.

APPENDIX A

**LEASE STANDARD TERMS AND
CONDITIONS**

Lease Standard Terms and Conditions

I. Definitions:

The following terms shall be defined as follows:

1. **Additional Rent** – Adjustable rent, up to a maximum annual amount of 5% of the preceding year's Additional Rent, shall be made to cover increases or decreases in the costs of real estate taxes, utilities, water, sewer, trash removal, insurance and janitorial services. The actual amount of the adjustment (increase or decrease) shall be determined by annually applying the CPI-U, NE Cities Index (Consumer Price Index for all Urban Consumers, Northeast Cities index, all items, as found in table 11 of the CPI Detailed Report published by the U.S. Department of Labor, Bureau of Labor Statistics) to the amount of the Additional Rent for the preceding year of the Lease. The Additional Rent shall not be adjusted to reflect actual costs incurred by Lessor during the term of this Lease, nor shall the amounts paid as Additional Rent be adjusted to reflect changes in the above Lessor costs.
2. **Base Rent** – Negotiated rent, not including Additional Rent, due to Lessor.
3. **Commencement Date** – The first day of the calendar month after the date the Premises are accepted for occupancy by the Lessee, as memorialized by the Using Agency's completion and execution of an "Acceptance of Leased Premises and/or Renovations Inspection Report" (GSRE-42-N(08-13), a sample of which is attached hereto as Exhibit 1.
4. **Common Areas** – Any space in a building affording common use for all tenants, with the exception of vertical penetrations (elevator shafts, flues, vertical ducting). Common Areas shall include but not be limited to building and elevator lobbies, corridors including but not limited to those leading from the elevator to the tenant space, restrooms, building break rooms, building conference rooms, janitorial closets and storage rooms.
5. **Commonwealth of Pennsylvania Standard Building Specifications** – The Commonwealth's standards for building, renovating, maintaining, operating, and repairing the Premises as set forth on Attachment B.
6. **Commonwealth of Pennsylvania Using Agency Building Specifications** – The Commonwealth of Pennsylvania's standards for building, renovating, maintaining, operating, and repairing the Premises as set forth on Attachment C. Items referenced in these specifications are specific to the Using Agency and may not apply to all Commonwealth leases.
7. **Consent Form** – A document signed by the Lessor, and approved by DGS/BRE, that states that the Lessor is aware of the Leasehold Improvement(s) requested by the Lessee and that the Lessor is allowing the Lessee to complete those Leasehold Improvements at Lessee's cost, as set forth on Exhibit 2.
8. **CPI** – The United States Bureau of Labor, Statistics, Consumer Price Index, all Urban Consumers, Northeast Cities Index, all items, as found in Table 11 of the CPI Detailed Report published by the U.S. Department of Labor, Bureau of Labor Statistics. The CPI-U, NE Cities Index reported four months prior to each anniversary of the Commencement Date shall be used to determine the amount of the adjustment to the Additional Rental Rate.
9. **DGS/BRE** – Department of General Services, Bureau of Real Estate.
10. **Execution Date** – Shall be the date the lease is signed by the Secretary of General Services after all other approvals have been obtained and shall be entered on the appropriate line of the first page of the Lease Cover Sheet.
11. **Expiration Date** – Shall be the date the lease is set to expire as identified on the Lease Cover Sheet.
12. **Initial Term** – Shall be the number of years identified on the Lease Cover Sheet that begins on the Commencement Date.

13. **Lease** – Is collectively comprised of all of the documents as identified on the Lease Cover Sheet.
14. **Lease Cover Sheet** – Shall include, but not be limited to, the name of the Lessor, the name of the Lessee, the Rent, the Initial Term, and the Net Usable Square Feet. Shall be the cover page to the Lease.
15. **Lease Amendment** – Written agreement between Lessor and Lessee which modifies the Lease.
16. **Leasehold Improvements** – Additions, alterations or improvements to the Premises and/or Common Areas, which occur after the Commencement Date.
17. **Lease Year** – Each successive twelve (12) month period starting on the Commencement Date.
18. **Lessee** – The Commonwealth of Pennsylvania, acting through the Department of General Services, on behalf of the Using Agency identified on the Lease Cover Sheet.
19. **Lessor** – Title owner that has the right to lease the Premises to Lessee.
20. **Net Usable Square Feet** – Shall be the number of square feet identified on the Lease Cover Sheet. Measurement computed by measuring the area to be used by the Using Agency from the inside perimeter walls surrounding this area, excluding stairwells, elevator shafts, public restrooms not within the leased space, mechanical and building equipment rooms and any area used by the Lessor. Lessor agrees that in a multiple tenant facility, if the building configuration requires a common access corridor serving more than one Commonwealth program area entrances, then that corridor space shall not be considered part of the net usable square footage.
21. **Normal Business Hours** – Monday through Friday 7:00 a.m. - 7:00 p.m. unless otherwise specified on the Lease Cover Sheet.
22. **Pre-Construction Meeting** – Meeting held between the Lessee, including but not limited to its agents, employees, licensees or invitees, and Lessor, including but not limited to its agents, contractors, subcontractors, employees, licensees, or invitees, after a lease or amendment is fully executed, but prior to any Work commencing on the leased Premises.
This meeting is intended to review and discuss final plans, timelines and concerns of all parties involved.
23. **Premises** -- The property or part of the property, more specifically described on the plan and/or specifications attached to this Lease and consisting of the amount of net usable square feet identified on the Lease Cover Sheet, together with Common Areas. Lessor and Lessee agree that the plan and/or specifications are subject to adjustment as agreed upon by the Lessor and Lessee, and in the event that there are adjustments to the plan and/or specifications, the Lessor and Lessee agree to replace any documents related hereto with a revised version of such document in order to accurately depict the Premises.
24. **Rent** – The monthly payment to Lessor by Lessee for use of the Premises, as determined by multiplying the amount of Net Usable Square Feet set forth on the Lease Cover Sheet by the Rental Rate. Rent shall be paid in equal monthly installments.
25. **Rental Rate** – The sum of the Base Rent and the Additional Rent, as set forth on the Lease Cover Sheet.
26. **Termination Date** – shall be the date the Lease is terminated with prior notification from the Lessee to the Lessor.
27. **Using Agency** – The Commonwealth of Pennsylvania Agency which occupies the leased Premises and is identified on the Lease Cover Sheet.
28. **Work** – Consists of the construction and renovation of the Premises substantially in accordance with all plans and specifications set forth on **Attachment B** and **Attachment C**.

II. Background:

1. By the *Act of April 9, 1929, P.L. 177, as amended, 71 P.S. Section 632(d)*, the Department of General Services is, with the approval of the Board of Commissioners of Public Grounds and Buildings, authorized and empowered to rent proper and adequate offices, rooms or accommodations for any department, board or commission which cannot be properly and adequately accommodated with offices, rooms and accommodations in the Capitol buildings.
2. Lessee desires to lease the net usable square footage, as defined on the Lease Cover Sheet, from Lessor for use by the Using Agency, upon the terms and conditions set forth in the Lease.
3. Lessor owns or has the right to lease the Premises to Lessee.
4. In consideration of the following mutual promises and intending to be legally bound hereby, Lessor and Lessee agree to the following Terms and Conditions:

III. Terms and Conditions:

1. **Incorporation of Definitions and Background Clauses.** Any and all background clauses, definitions and Exhibits are incorporated into the Lease by reference.
2. **Premises.**
 - a. Lessor leases the Premises to Lessee for use and occupancy by the Using Agency, and Lessee leases the Premises from Lessor for use and occupancy by the Using Agency.
 - b. The Net Usable Square Feet shall be subject to verification, in accordance with the procedure set forth in Paragraph 17 "Completion" below. Lessee shall have the right to use any space within the Premises in excess of the Net Usable Square Feet without the requirement to pay any additional rent, costs or charges. In the event the actual net usable square feet is less than the Net Usable Square Feet, then, Lessee shall have the right to (i) reduce the amount of Net Usable Square Feet and pay for the reduced amount of the Net Usable Square Feet; or (ii) terminate the Lease without liability for any costs or future rent, if Lessee determines, in its sole judgment, that the actual amount of Net Usable Square Feet provided is insufficient to meet Lessee's needs.
 - c. Lessor shall lease the number of parking spaces to Lessee as referenced on the Lease Cover Sheet. Lessor agrees that these parking spaces are included in the Rental Rate for the Premises as set forth on the Lease Cover Sheet. Lessor agrees that there is no additional payment due for these parking spaces.
3. **Term.** The Initial Term of the Lease shall be the number of years referenced on the Lease Cover Sheet. The Initial Term shall begin on the Commencement Date and end, without the necessity of notice from either party to the other, on the expiration of the number of years in the term, subject to the renewal options set forth on the Lease Cover Sheet.
4. **Rent.**
 - a. Lessee shall pay Lessor Rent for the use and occupancy of the Premises.
 - b. The Rental Rate for all succeeding Lease Years, including any option terms, shall be calculated by Lessee, without the necessity of a request from Lessor, as follows:
 - i. Multiply the percentage of change in the CPI by the Additional Rent for the then current Lease Year. The resulting product will equal the amount of increase or decrease in the Additional Rent for the succeeding Lease Year.
 - ii. The amount of the increase or decrease shall be applied to the Additional Rental Rate for the current Lease Year, to arrive at the Additional Rent for the succeeding Lease Year. The

adjusted Additional Rent will then be added to the Base Rent to calculate the Rental Rate for the succeeding Lease Year.

5. **Rent Payments.**

- a. Lessee shall make Rent payments electronically through Automated Clearing House (“ACH”). Lessor shall complete the Pennsylvania Electronic Payment Program (PEPP) Enrollment Form, which is available at: <https://www.vendorregistration.state.pa.us/cvmu/paper/Forms/ACH-EFTenrollmentform.pdf>.
 - i. No later than 10 days after Lessor’s receipt of the executed Lease, Lessor shall submit the completed PEPP Enrollment Form by fax to the Commonwealth of Pennsylvania, Vendor Data Management Unit, Payable Service Center at 717-214-0140, or by mail to the Commonwealth of Pennsylvania, Office of Budget, Payable Services Center, 555 Walnut Street – 9th Floor, Harrisburg, PA 17101.
 - ii. It shall be the responsibility of the Lessor to ensure that the ACH information submitted is correct and to ensure the most current information is provided to the Vendor Data Management Unit throughout the term of the Lease. Failure to timely submit and maintain accurate and complete ACH information may result in delays in Rent payments.
 - iii. Lessor hereby acknowledges and agrees that failure to timely submit and maintain accurate and complete ACH information may result in delays in Rent.
- b. Lessee reserves the right, upon thirty (30) days prior written notice to Lessor, to offset future Rent payments to recover any prior Rent overpayment made by Lessee to Lessor.
- c. Lessor agrees that Lessee may offset the amount of any state tax liability or other obligation of Lessor or its subsidiaries to the Commonwealth against any payments due the Lessor under any contract with the Commonwealth.

6. **Taxes.** Lessor shall pay, in a timely manner, all real estate taxes and municipal, general and special assessments and other taxes of any nature applicable to the Premises and the Common Areas, as well as the parking spaces subject to this Lease, directly to the taxing authority.

7. **Non-Appropriation/Cancellation.** It is understood and agreed between the parties hereto that if the governmental function for which the Premises are being leased, is abolished, limited, or restricted, by any Act of Legislature, including a failure of sufficient appropriation by the General Assembly to continue payment of the Rent or any other amount hereunder, or by Law of Congress, or by any Action taken under authority conferred by such acts or laws, or decision of court; then the Lessee shall have the right to cancel this Lease by giving one month's notice in writing. At the option of the parties, if they have agreed on the total costs of renovations prior to the execution of this Lease and the Lease is canceled pursuant to the provisions of this Paragraph, if the Agency's annual appropriations permit, Lessee shall reimburse Lessor for any unamortized costs of renovations performed by Lessor pursuant to this Lease at Lessee’s request, and which are peculiar to Lessee’s tenancy.

8. **Termination for Convenience.** In addition to any rights of termination already contained in the Lease, Lessee is hereby granted the right to terminate this Lease in accordance with this clause whenever the Lessee shall determine in its sole discretion that such termination is in the best interest of the Lessee. Lessee must provide at least six (6) months prior written notice to Lessor of the intended date of termination. Such termination date may not be prior to the expiration of at least fifty percent (50%) of the initial term of this Lease. In the event Lessee exercises this option to terminate for its convenience, Lessee shall pay Lessor a sum equivalent to three (3) months Base Rent as an early termination fee (early termination fee). In addition to the early termination fee, if the parties have agreed on the total costs of renovations prior to the execution of the Lease and the Lease is cancelled by Lessee pursuant to the provisions of this Paragraph, Lessee shall reimburse Lessor for any unamortized costs of renovations performed by Lessor pursuant to this Lease at Lessee’s request, and which are peculiar to Lessee’s tenancy.

Upon payment of the early termination fee, and any unamortized costs (if applicable), Lessor releases Lessee from any claims whatsoever, at such time or in the future, whether known or unknown, for any damages, consequences or liabilities associated with Lessee’s exercise of this Termination for Convenience clause.

9. **Options.** Lessee, at its sole discretion, shall have the option to renew this Lease for additional terms as identified on the Lease Cover Sheet. In order to exercise an option, Lessee must give Lessor three (3) months' prior written notice before the expiration of the then current term of this Lease. The Rental Rate for each option term shall be calculated by adding the Additional Rent to the Base Rent for the option term.
10. **Holdover/Termination.** Should Lessee holdover in possession after the expiration of the Initial Term of this Lease (without exercising any option to renew), or after the expiration of any renewal term (without exercising any remaining option to renew), such holding over shall not be deemed to extend the term of this Lease or any renewal term, but the tenancy thereafter shall continue from month to month, subject to the covenants and conditions of this Lease, until either party shall give the other three (3) months' notice in writing of its intention to terminate the tenancy. During any such holdover periods, the Base Rent will remain the same, for a period of three (3) months, as it was prior to the expiration of the term. Effective on the first day of the fourth month of any holdover period, the Lessee shall pay the amount of the Base Rent specified for the Option period as identified on the Lease Cover Sheet.
11. **Lessor's Duty to Mitigate Damages.** In the event Lessee abandons the Premises prior to the end of the then-current lease term, Lessor shall have an affirmative duty to proceed in good faith and with due diligence to make reasonable efforts to mitigate its damages and prevent further loss.
12. **Lessee's Alteration Rights.** For the life of the Lease, the Lessee must be offered the option to upgrade existing space for operational use, or to make additional alterations and renovations to the facility. In situations when the Lessor pays the upfront costs for the renovations or upgrades to the existing space, Lessor and Lessee hereby agree and acknowledge that the Lessee will reimburse Lessor.
13. **Utilities**
- a. Lessor shall, at its sole cost and in return for Rent paid by Lessee pursuant to this Lease, provide, maintain, and pay the costs and periodic charges for, the following:
- i. Heat, ventilation and air conditioning ("HVAC") for the Premises and all Common Areas in accordance with the standards set forth in **Attachment B**;
- ii. All energy and utilities provided, used and consumed on the Premises and the Common Areas, including but not limited to gas, oil, electric, steam, water and sewer; except usage charges for telephone, CATV, internet and other communication services utilized by Lessee, which shall be arranged for and paid by Lessee;
- iii. Hot and cold water to the Premises and the Common Areas (including restrooms within or serving the Premises); and
- iv. Passenger and freight elevator services (including loading dock access and use) for access within, to and from the Premises. Lessor shall make no change in the elevator service provided to Lessee after the Commencement Date, without the Lessee's prior written consent.
- b. Lessor shall, at its sole cost and in return for Rent paid by Lessee, provide access and consent to install or connect telecommunications cabling and equipment, including but not limited to telephone, CATV, high speed data transmission and internet connectivity on each floor of the Premises, occupied by Lessee, Lessor shall coordinate with the Using Agency designee and selected provider to arrange for such installation and connection through such infrastructure at Lessor's expense and in accordance with **Attachment B** and **Attachment C**. Additional changes or upgrades to the voice and data system after the initial scope of work is completed will be at the Lessee's expense and Lessor will provide access and consent to install.
- i. The amount of Rent presumes a normal work week and hours for the Using Agency employees of Monday through Friday, from 7:00 A.M. to 7:00 P.M., unless otherwise specified in **Attachment C**. Lessee shall have the right to use the Premises seven days a week, twenty-four hours a day.
- c. All other utility services, and elevator service, shall be maintained to the Premises and the Common Areas at the same level of service during all hours as during normal business hours, without additional cost to Lessee.

14. **Services.**

- a. *Ice and Snow Removal.* Lessor is responsible for snow and ice removal of sidewalks and parking areas within four hours after cessation of snow, sleet or icing weather. It is the Lessor's responsibility to correct all unsafe conditions relating to freezing and thawing. Lessor is responsible for the cleaning/repairing and maintenance of the roofs, gutters and awnings. Gutters should be cleaned on a regular basis and snow and sleet should be removed within four (4) hours of cessation.
- b. *Janitorial Services.* Lessor shall provide janitorial services as outlined in **Attachment B.**
- c. *Landscaping, Finish Grading, and Seeding.* Lessor shall furnish all labor, materials, and equipment as necessary to complete topsoil spreading, finish grading, sodding, seeding, and shrubbery planting as required to produce a uniform, weed-free stand of grass and acceptable landscaping. Lessor is responsible for maintaining shrubs, grass, including but not limited to mowing, and landscaping for the life of the lease.
- d. *Trash Dumpster/Trash Cans.* Lessor shall provide a designated trash area adjacent to the facility of a sufficient size to accommodate an appropriate commercial sized trash dumpster for solid waste. Lessor will maintain a waste management contract for the life of the lease. Individual trash cans capable of holding .5 gallons to 5 gallons and recycle cans capable of holding up to 5 gallons will be provided, collected and maintained for each workstation and office by the Lessor.
- e. *Recycling: Ordinances and Regulation.* Lessor shall:
 - i. Establish and maintain a separation and collection procedure for the removal of recyclable materials from the leased Premises;
 - ii. Collect, at a minimum, aluminum, high grade office paper, and corrugated paper;
 - iii. Comply with Act 101 of 1988 and any existing local codes and ordinances relating to the separation and disposal of recyclable materials;
 - iv. Provide suitable containers, dumpsters, etc., for collecting and storing recyclable materials;
 - v. Empty all recycling receptacles and remove recyclables to a designated area as often as necessary taking into consideration the volume of the recyclables and health concerns; and
 - vi. Assume all costs involved in collecting, storing and removing recyclables.
 - vii. Lessee reserves the right to identify those recyclable materials, generated from agency operations at the leased Premises, which Lessee desires to sell as serviceable property. Lessee reserves the right to dispose of such materials itself. When and if the Lessee exercises this discretion, the Lessor shall thereafter not be responsible for those materials selected by the Lessee for disposal by the Lessee.

15. **Maintenance and Repairs.** Lessor, at its sole cost and in return for Rent paid by Lessee, shall maintain, repair, replace and provide the continuous upkeep of the exterior of the building and all internal building systems, including but not limited to, electrical, lighting, plumbing, heating, ventilation equipment, air conditioning, elevators, escalators, and/or lifts, as set forth herein and as more specifically stated in **Attachment B** and **Attachment C.** Lessor shall not be responsible for damages caused by Lessee's negligence, or the negligence of Lessee's employees or agents. Service response times must be within twenty four (24) hours.

- a. *Maintenance Contracts.* Lessor shall secure maintenance service contracts, with certified service providers, for the life of the Lease, in the following areas: roof, HVAC systems, and elevators in compliance with **Attachment B.**
- b. *Elevators.*
 - i. All elevator equipment and systems shall be in operating order 24 hours per day and shall be serviced and maintained by the Lessor for the term of the Lease.

- ii. Lessor shall provide proof of semi-annual preventative maintenance and/or repairs to all elevator equipment and systems. The reports shall be provided in writing within 30 days of completion of any service and/or repairs to the DGS/BRE, Room 503, North Office Building, Harrisburg, PA 17125. The semi-annual maintenance will include, but is not limited to, the service of the following items: Hydraulics, cables, controllers.
 - iii. All elevator equipment and systems should be inspected bi-annually by a 3rd party certified inspector. If the elevator is found to be non-compliant, then an inspection will be completed by the Department of Labor and Industry. If the elevator is constructed prior to 2004 it must comply with 34 PA Code Chapter 7; if the elevator is constructed after 2004, the inspection must comply with ASME A17.1.
 - iv. Lessor shall notify Lessee at least one (1) day in advance of taking the elevator offline for maintenance and/or repair and give Lessee an estimated completion date of the maintenance and/or repair and when the elevator will be back online.
 - v. Lessor shall respond to an elevator entrapment within thirty (30) minutes of notification. If the Lessor fails to respond within thirty (30) minutes, the Lessee shall charge the Lessor Seventy-Five Dollars (\$75.00) for each failure to respond.
 - vi. Should more than three (3) elevator entrapments happen within six (6) months, then the Lessor shall have all elevator equipment and systems inspected and repaired within thirty (30) days of request by Lessee. Lessor shall provide Lessee a written report of the inspection and repair work of the elevator equipment and systems within five (5) business days of the completed inspection and within five (5) business days of the completed repair work.
 - vii. Lessor shall provide Lessee with a yearly preventative maintenance schedule for all elevator equipment and systems.
- c. *Lighting.* Lessor shall provide, install and replace all light bulbs, tubes, ballasts and starters. This stipulation also includes the parking area(s). All lighting shall be maintained as specified in **Attachment B**.
- d. *Heating, Ventilation and Air Conditioning.*
- i. All HVAC systems shall be designed, maintained and operated in a manner which maximizes energy efficiency. All equipment and systems shall be in operating order twenty-four (24) hours per day and shall be serviced and maintained by Lessor. Systems shall be inspected and serviced regularly to ensure proper balancing and calibration.
 - ii. Heating and air conditioning systems shall provide and maintain an inside automatically controlled temperature in accordance with **Attachment B**. Failure to follow **Attachment B** shall be considered a violation of the Lease.
 - iii. Lessor shall provide proof to Lessee of routine semi-annual maintenance/repairs to HVAC systems and respective components. Lessor shall provide the written reports to Lessee within thirty (30) days of completion of any service/repairs. The semi-annual maintenance will include, but is not limited to the service of the following items: boilers, boiler stacks, chillers, air handling units, coils, filters, belts, cooling towers, pumps, chilled water cooling systems, hot water heating systems, compressors, fan coil units, heat pumps, HVAC system controls, changing filters, checking baffles, ductwork, damper positions and system balance.
 - iv. All HVAC systems shall be tested and inspected by Lessor prior to Lessee occupancy to determine if the environmental conditions, as stated in the Lease, are met, and if adequate ventilation is provided for each area in accordance with the most current standards and guidelines of the American Society of Heating, Refrigerating & Air Conditioning Engineers ("ASHRAE"). Upon completion of testing and inspection, a certified report, signed by a registered engineer, who is certified by the National Environmental Balancing Bureau (NEBB), shall be submitted to the DGS/BRE, Room 503 North Office Building, Harrisburg, PA. 17125. The report shall be valid proof that the systems have been tested, adjusted, and balanced in accordance with the referenced standards, and be a true representation of how the systems are operating.

- v. Lessor shall be responsible throughout the term of the Lease to provide, at the request of Lessee, testing of the environmental conditions within the Premises, to include the submission of a detailed report signed by a registered engineer. The report should include recommendations for HVAC system modifications, if required to provide adequate ventilation and environmental conditions as stated per the Lease.
- vi. Lessor shall provide Lessee with a yearly preventative maintenance schedule for all HVAC systems.
- e. *Certification.* Lessor shall submit, within one (1) month after the Commencement Date, and for each year thereafter, current certifications for all service contractors referenced in this Paragraph, **Attachment B**, and **Attachment C** to prove that all service systems are being serviced and inspected on an acceptable periodic basis.
- f. *Building Manager.* Lessor shall have a building superintendent or a locally-designated representative available to proactively manage the Premises and to promptly respond to Lessee's requests to correct any deficiencies.
- g. *Painting.*
 - i. Lessor shall repaint the Premises every five (5) years during the term of this Lease, and any option terms, after Normal Business Hours. Lessor shall be responsible for the cost of moving furniture and equipment. Lessor shall contract with the furniture vendor selected by Lessee to move the furniture and equipment. Lessor shall notify Lessee at least forty-eight (48) hours in advance of repainting. Any repainting of the Premises, in whole or in part, may be waived by Lessee if it is determined that such repainting is not necessary.
 - ii. Lessor shall, upon Lessee's request, repaint portions of the Premises more frequently, if necessary, to maintain an appropriate appearance.
 - iii. Should the Premises contain lead-based paint, Lessor shall be responsible for the abatement of the lead-based paint in accordance with state and federal standards, whichever standards are higher or most stringent shall prevail.
- h. *Parking Lot.* Lessor shall be responsible, throughout the term of the Lease, for the maintenance and repair, including but not limited to, the black top of the Parking Lot. Lessor shall respond within ten (10) business days of notification by Lessee of holes and/or cracks, which pose a safety hazard, in the Parking Lot.

16. **Construction or Renovations.** Lessor shall:

- a. Construct and renovate the Premises, at Lessor's sole cost and expense, and in return for Rent paid by Lessee, in accordance with all plans and specifications set forth in **Attachment B** and **Attachment C**, and within the dates set forth in the Construction Completion Timeline Section of the Lease Cover Sheet; and
- b. Not begin any construction or renovation until after the Lease has been executed and a Pre-Construction Meeting has been held; and
- c. Comply with all applicable local, state and federal construction codes, regulations, statutes, ordinances and laws, applying whichever is most stringent. All work shall conform to the latest standards of the trade; and
- d. Furnish all labor, superintendence, materials, tools and equipment and perform all work necessary to complete all construction to the satisfaction of the Lessee; and
- e. Complete all general construction work in accordance with the Work as shown in **Attachment B** and **Attachment C**; and
- f. Not use any construction materials containing asbestos. If Lessor is renovating a space and finds friable materials containing asbestos, then Lessor shall remove the friable materials containing

asbestos in accordance with OSHA and EPA regulations. Contractors need to be trade specific licensed/certified to remove the friable materials containing asbestos; and

- g. Shall restore the area in such a manner that is acceptable to Lessee; and
- h. Shall comply with the Americans with Disabilities Act (ADA), whether or not specifically mentioned in the specifications or depicted on the drawings. All work must be in accordance with all local, state, and federal codes and regulations, whichever is most stringent, regarding ADA.

17. Completion.

- a. Upon receipt of an executed copy of this Lease, Lessor shall, all in accordance with the dates set forth in the Construction Completion Timeline Section of the Lease Cover Sheet, undertake the following:
 - i. Within thirty (30) days, furnish Lessee with detailed plans, specifications, drawings and other relevant construction documents (collectively, "Documents") pertaining to the construction and/or renovation;
 - ii. Within thirty (30) days after the receipt of the Documents, Lessee shall then review and either approve or reject the Documents. Lessor and Lessee agree that the approved Documents shall depict, as accurately as possible, the Premises. In the event Lessee's review exceeds thirty (30) days, the completion schedule shall be extended accordingly to incorporate the number of days exceeding the initial thirty (30) day review period;
 - iii. Within thirty (30) days of Lessee's approval of the Documents, Lessor shall then commence the construction and/or renovation in accordance with the approved Documents;
 - iv. Within thirty (30) days after Lessee has approved of the Documents, provide Lessee with a construction timeline;
 - v. Shall have the entire project completed, including final clean-up and the securing of all occupancy licenses or permits required by any governmental entity for occupancy, within One Hundred Eighty (180) days;
- b. Upon completion of the Work, to prove that the Premises are ready for occupancy, Lessor shall, at Lessor's expense:
 - i. Arrange for field measurements of the Premises and verification of the Net Usable Square Footage by a licensed architect and/or engineer;
 - ii. Provide Lessee with a written certificate from Lessor's architect/engineer that shall include a sealed set of drawings showing, in red, any changes in the dimension of the Premises, or in the Net Usable Square Feet, from the last set of drawings which Lessor provided to the DGS/BRE. The certificate shall: (i) include the date(s) when the measurements were done; (ii) specify the Net Usable Square Feet; and (iii) state that the Net Usable Square Feet were determined based upon the Commonwealth's net usable square footage definition. The certificate must be signed by the architect/engineer and bear such professional's seal. The Net Usable Square Feet shall be subject, at any time, to verification by Lessee;
 - iii. Furnish complete as-built drawings of the completed structure in an AutoCAD version and format acceptable to Lessee, together with hard copy drawn to a minimum 1/8 inch = 1 foot scale;
- c. Unless Lessee has agreed, in writing, to an extension of the completion date for the Work, if Lessor fails or refuses to comply with the provisions in this Paragraph, Lessee, after giving Lessor thirty (30) days' notice, in writing, shall have the right to terminate this Lease and/or exercise any other remedy it may have under the Lease or at law. Furthermore, in addition to these rights, Lessor must pay Lessee, at Lessee's option, as liquidated damages, one percent (1%) of the first year's annual Rent under this Lease for each and every day the Premises are not ready for occupancy by the date provided herein.

- d. No Rent shall be due or payable until:
 - i. Lessee completes and signs the Acceptance of Leased Premises and/or Renovations Inspection Report (GSRE-42-N (08-13) as set forth on **Exhibit 1** attached hereto; and
 - ii. Lessor has complied with all other provisions of this Lease.

18. **Certificate of Occupancy.**

- a. Lessor shall furnish and visibly display a copy of a Certificate of Occupancy, issued by any and all Federal, state, and local government entities, at the time of occupancy by Lessee of the Premises.
- b. If Lessee, after notifying Lessor prior to the action, increases or decreases staff, Lessor shall be responsible to make sure the Premises remains in compliance with all Federal, state, and local codes, regulations, and/or ordinances in relation to occupancy.

19. **Leasehold Improvements.**

- a. For any and all Leasehold Improvements completed by Lessor, at the request of Lessee, Lessor and Lessee agree and acknowledge that any Lease Amendment, or the Consent Form attached hereto and marked as **Exhibit 2**, must be executed and delivered to Lessor before any Leasehold Improvement is started.
- b. For any and all Leasehold Improvements completed by Lessee, Lessor and Lessee agree and acknowledge that a Consent Form must be executed and delivered to Lessor before any Leasehold Improvement is started.
- c. For any and all Leasehold Improvements requested by Lessee, Lessor and Lessee agree and acknowledge that:
 - i. Lessor shall obtain three (3) quotes from three (3) separate contractors/vendors for the Leasehold Improvement and submit all three (3) quotes to Lessee.
 - ii. A Consent Form or Lease Amendment must be executed and delivered to Lessor before any Leasehold Improvement is started.
- d. Any and all Leasehold Improvements shall be constructed in compliance with all applicable local, state and federal codes, regulations, statutes, and/or ordinances, applying whichever are most stringent.
- e. The Premises shall be restored in a manner that is acceptable to Lessee, when the Leasehold Improvement is completed by Lessor, or acceptable to Lessor, when the Leasehold Improvement is completed by Lessee.

20. **Fire/Safety.** Lessor shall:

- a. Provide, monitor, and maintain, at Lessor's expense, an NFPA compliant fire alarm and evacuation system that is in compliance with all Federal, state, and municipal laws, ordinances and regulations.
 - i. The fire alarm and evacuation system shall be audible and visual.
 - ii. The fire alarm and evacuation system shall be operational twenty-four (24) hours a day, seven (7) days a week.
 - iii. Lessor shall be responsible for providing, installing and maintaining a dedicated voice analog/digital telephone line for the fire and security systems.
 - iv. Lessor shall have the fire alarm and evacuation system serviced and tested annually, in compliance with **Attachment B**; and Lessor shall furnish proof of same to Lessee upon request. All testing of the fire alarm and evacuation system shall occur after Normal Business Hours.

- v. Lessor shall provide Lessee a yearly maintenance schedule for the fire alarm and evacuation system.
- vi. Lessor shall provide ongoing training of the fire alarm and evacuation system, as requested by Lessee, during the term of the Lease.
- b. Provide, monitor, and maintain, at Lessor's expense, an NFPA compliant fire suppression system, including but not limited to fire extinguishers and sprinklers, in compliance with all Federal, state, and municipal laws, ordinances and regulations.
 - i. Lessor shall have the fire suppression system serviced and tested annually, in compliance with **Attachment B**, and furnish proof of same to Lessee upon request. All testing of the fire suppression system shall occur after Normal Business Hours.
 - ii. Lessor shall provide Lessee a yearly maintenance schedule for the fire suppression system.
 - iii. Lessor shall provide ongoing training, as requested by Lessee, during the term of the Lease, of the fire suppression system.
 - iv. Lessor shall be responsible for the inspection and recharging of all fire extinguishers.
- c. Coordinate with the Using Agency a bi-annual Emergency Evacuation Drill.
- d. Prior to any installation and/or updates to either the fire alarm and evacuation system or the fire suppression system or the security system, obtain Lessee's approval of the installation and/or update.
- e. Upon request from Lessee, provide a new locking system and/or associated hardware, after a break-in or a series of thefts or other similar unusual occurrences at the Premises.
- f. Annually test and inspect, without an additional charge to Lessee, any and all other safety systems, including but not limited to emergency generators, on the Premises to ensure proper operation. All testing and inspections shall be done in compliance with all applicable Federal, state, and municipal laws, ordinances and regulations.
- g. Shall display any and all inspection certificates as appropriate and shall provide any and all inspection certificates to Lessee upon Lessee's request.

21. **Insurance.**

- a. At all times during the term of the Lease, Lessor shall procure and maintain, at its expense, the following types of insurance, issued by companies acceptable to Lessee and authorized to conduct such business under the laws of the Commonwealth of Pennsylvania:
 - i. Worker's Compensation Insurance for all of Lessor's employees and those of any contractor engaged in work at the Premises, in accordance with the Worker's Compensation Act of 1915 and any supplements or amendments thereto.
 - ii. Public Liability Insurance to protect Lessee, Lessor and any and all contractors from claims for damages for personal injury (including bodily injury), sickness or disease, accidental death and damage to property, including loss of use resulting from property damage, which may arise from services performed by Lessor, its agents or employees under this Lease, or from an alleged defective, dangerous or untenable condition of the Premises. The limits of such insurance shall be in an amount not less than \$500,000 each person and \$2,000,000 each occurrence. Such policy shall name the Commonwealth of Pennsylvania as an additional insured.
 - iii. Builders Risk. During the period of any construction of the Premises or the building (including, without limitation, the Work), Lessor shall purchase and maintain (or shall cause its general contractor to purchase and maintain) Builders Risk "All Risk" or equivalent policy form in the amount of the initial construction contract sum plus the value of subsequent contract modifications and the cost of materials supplied or installed by others, comprising the total value of the entire Building on a replacement cost basis without optional deductibles. Such

property insurance shall also cover portions of the Work stored off the site and portions of the Work in transit. Such insurance shall, unless otherwise agreed in writing by all persons and entities that are beneficiaries of such insurance, (a) be maintained until the construction project is complete, (b) include at least the interests of Lessor, Lessee, and any and all contractors, and (c) include Loss of Use insurance due to a covered loss, including Leasehold Interest Coverage in favor of Lessee subject to a minimum limit of twice the Rent due for the first Lease Year. The period of coverage for this Loss of Use shall be, at a minimum, the length of the original construction period of the applicable construction project.

- iv. Property. At all other periods during the term of the Lease, Lessor shall provide "All-Risk" or equivalent property insurance covering the Building and appurtenant structures and improvements up to the full replacement cost thereof, including all fixtures, equipment, machinery and apparatus which constitute a permanent part of such Building, and other structures and improvements. If the coverage is available and commercially appropriate (with commercially appropriate sublimits), such property insurance shall insure against all risks of direct physical loss or damage including without limitation the perils of fire (with extended coverage), and physical loss or damage including theft, vandalism, malicious mischief, collapse, earthquake, flood, windstorm, and boiler/machinery. Such policy shall also include coverage for debris removal and the enforcement of any legal requirements requiring the upgrading, demolition, reconstruction or replacement of any portion of the Premises as the result of a covered loss. Such policy shall permit partial occupancy as construction progresses.
- b. At all times when Lessor is obligated to maintain insurance coverage as provided in this Paragraph, Lessor shall comply with the following requirements:
- i. All policies will be issued by carriers having ratings of Best's Insurance Guide A- or better, or its substantial equivalent if such Guide is no longer published, and admitted or permitted to engage in the business of insurance in the Commonwealth of Pennsylvania for the past five years. If any coverage is provided by an unrated captive, such captive will have financial resources of equivalent standing to those meriting a rating of Best's Insurance Guide A- or better, with audited financials of the captive to be furnished annually to Lessee.
 - ii. Any non-standard policy or endorsement other than as specified herein must be approved in advance in writing by Lessee, which approval shall not be unreasonably withheld, conditioned or delayed. No policy will contain a deductible or self-insured retention in excess of the limits set forth above, unless mutually agreed by Lessor and Lessee in their sole discretion.
 - iii. If the forms of policies, endorsements, certificates, or evidence of insurance required hereunder are superseded or discontinued, Lessee will have the right to require Lessor to provide other substantially equivalent forms consistent with the standards observed by prudent and reputable owners of office buildings of the same class as the Building, in the locality of the Building. Evidence of the insurance coverage required to be maintained by Lessor hereunder, represented by certificates of insurance issued by the insurance carrier(s) and constituting actual evidence of coverage, must be furnished to Lessee, at the address set forth in Paragraph 36 "Notice," at least thirty (30) days prior to the Commencement Date, and at least thirty (30) days prior to the expiration of current policies. Such certificates will specify the additional insured status (as applicable) of the Commonwealth of Pennsylvania. Such certificates will state that persons and parties required to be named hereunder as additional insureds have been so named, and that such additional insureds will be notified in writing thirty (30) days prior to cancellation, material change, or non-renewal of insurance. The "endeavor to" language contained in any cancellation notice section of such certificate shall be deleted. Such certificates, or a separate writing issued by the insurer or its agent together with such certificate, shall set forth the amounts of deductibles and all self-insured retentions.
 - iv. If Lessor fails to comply with its covenants made in this Paragraph, Lessee may, at its option, cause insurance as aforesaid to be issued, and in such event Lessor agrees to pay the premium for such insurance promptly upon Lessee's demand.
 - v. Lessor may carry any insurance required by this Paragraph under a blanket policy, applicable to the property to be insured hereunder for the risks and in the amounts required pursuant to

this Paragraph, provided that all requirements of this Paragraph shall be complied with in respect of such policy.

vi. If requested in writing, Lessor shall provide to Lessee a certified copy of any and all insurance policies or endorsements required by this Lease, and Lessor shall provide such certified policies to Lessee within thirty (30) days after written request is made. These certificates shall contain a provision that the coverage afforded under the policies will not be canceled or changed until at least thirty (30) days' written notice has been given to Lessee.

i. All liability insurance to be maintained by Lessor shall be on an occurrence basis.

c. At least thirty (30) days prior to the Commencement Date, Lessor shall provide Lessee with evidence, reasonably satisfactory to Lessee, that Lessor requires any other tenants of the Building to carry commercial reasonable limits of liability insurance to respond to liability exposures associated with such other tenants' occupancy of the Building.

22. **Hold Harmless.** Lessor shall save and hold harmless Lessee, and its officers, agents and employees, or any of them, from any and all claims, demands, actions, damages, losses liability, and expense (including, but not limited to, consequential damages and reasonable attorney's fees) of any nature based upon or arising out of:

a. Any service performed by Lessor, its agents or employees under this Lease, except such services as are properly performed at the express direction of Lessee; or

b. Any actual or alleged defective, dangerous or untenable condition of the Premises; or

c. Violations of, or noncompliance of the Premises, any statute, ordinance, rule or regulation of any governmental authority, or violations of, or noncompliance with, any statute, ordinance, rule or regulation of any governmental authority on the part of Lessor, its employees, agents or contractors; or

d. Any breach of any of the covenants, representations or warranties of Lessor contained in this Lease; or

e. Any personal injury, death or damage to property caused by Lessor, its employees, agents or contractors.

23. **Damage/Destruction.** In the event of damage to the Premises by fire, flood, lightning, or other Act of God, or act of terrorism rendering it impossible or substantially inconvenient for Lessee to continue to occupy or use the Premises for its operations, the Lessor, after notice from the Lessee of the condition shall have sixty (60) days to repair and/or restore the Premises to a tenantable condition. If Lessor fails to repair and/or restore the Premises within said period of sixty (60) days, or if Lessor fails to make reasonable progress during the sixty (60) day period, as determined by Lessee in its sole discretion, Lessee may, at its option: a.) terminate this Lease by giving Lessor thirty (30) days' written termination notice or b.) after first giving Lessor fifteen (15) days' written notice, repair and restore the Premises to a tenantable condition, and deduct such costs made in restoration of the Premises from the Rent due the Lessor. At Lessee's option, payment of Rent shall abate as long as the Premises remains in an untenable condition after notice to Lessor and shall resume only after the condition has been substantially corrected. Such abatement shall be prorated on the portion of the Premises that is or remains untenable.

24. **Encumbrances.** Lessor covenants:

a. That it has good and clear title to the Premises, or that it has the right and authority from the owner of the Premises, to lease the Premises to Lessee.

b. That Lessee shall enjoy peaceful and uninterrupted possession of the Premises during the term of this Lease.

c. That Lessor shall execute and provide to Lessee and any mortgagee which may hold an encumbrance against the Premises, a reasonable Subordination, Non-Disturbance and Attornment Agreement with respect to matters related to this Lease and/or the status of performance of obligations by the parties under this Lease.

25. Regulations.

- a. With full understanding by Lessor of the intended use of the Premises by Lessee, Lessor shall ensure that the Premises conform to all applicable laws, codes, ordinances, rules and regulations (collectively, "Regulatory Requirements").
- b. Lessor, at its sole expense, shall promptly take action to comply with changes in any Regulatory Requirements when such changes occur during the term of this Lease and any renewal thereof.
- c. Lessor shall be responsible for the payment of any signage fees imposed by local governmental authorities.

26. Communication Lines.

- a. Subject to all applicable governmental requirements and restrictions, Lessee shall have a non-exclusive right to install, maintain, upgrade, operate, repair and replace, at Lessee's cost, on the roof of the Premises "Rooftop Communication Devices" or "RCD".
 - i. RCD may include, without limitation, a back-up generator, and transmitter(s), microwave or satellite dishes or antenna(s), or other communications fixtures or equipment utilized for receiving or transmitting voice, video, data or other communications, together with all wiring, equipment and facilities reasonably necessary to make the same functional and connected with the Premises.
 - ii. The RCDs shall be for the sole use of Lessee in the operation of their business within and outside the Premises (including, without limitation, public broadcast services), but not for any sublicense for profit.
- b. Subject to all applicable governmental requirements and restrictions, Lessee shall have a non-exclusive right to interconnect the RCD with Lessee's other equipment located in the Premises using risers, conduits, chases, and other mutually agreeable locations in the Premises.
- c. If the Lessee desires to install voice, data or other communications lines (including, without limitation, fiber optic lines) to the Premises, or to communications equipment devices serving the Premises but located outside of the Premises, Lessor shall approve, which approval shall not be unreasonably withheld, delayed or conditioned.
 - i. The allocation of space in risers and conduits not installed by Lessee;
 - ii. The installation of risers and conduits by Lessee;
 - iii. The use of mechanical or equipment space, and appropriate shielding.
- d. In the event of any conflict between any use or installation made, or proposed to be made, by Lessee with any other occupants, tenants, or users of Lessor's building, if such conditions should exist, Lessor shall use its good faith best efforts to afford Lessee priority in such use or installation of communication lines, consistent with Lessor's existing obligations to other occupants, tenants or users of Lessor's building and Lessor's operation of their building.
- e. Lessor shall cooperate with Lessee in establishing protocols enabling Lessee and Lessee's contractors to obtain immediate access to communications rooms within the Premises and/or Lessor's building which contain Lessee's communications equipment.

27. Vending.

- a. Lessee reserves the right to install and operate vending machines on the Premises without any additional payment to Lessor or any sharing of the income derived from the operation of the vending machines.
- b. Lessor shall not install or operate any vending machines in the Premises unless agreed upon by the Using Agency.

- c. If the Premises are located in a multi-tenant building, Lessor may install vending machines in the Common Areas of the Building.
- d. All receipts from the operation of vending machines, after costs of goods sold, and all commissions paid by a commercial vending concern, shall accrue to the licensed blind vendor operating the vending machines on the Premises or, if none, to the Commonwealth Employment Fund for the Blind, as required by the "*Little Randolph-Sheppard Act*", 71 PS §§ 580.1-20.

28. Asbestos.

- a. Lessor represents and warrants that the Premises and/or Lessor's building and/or any of Lessor's building systems or components serving the Premises, and all Common Areas of the Premises will, no later than the Commencement Date, be free of any and all asbestos and asbestos containing materials not properly encapsulated or enclosed in compliance with all applicable law and governmental requirements, without cost or expense to Lessee.
- b. Lessor shall complete and sign the Asbestos Certification attached hereto and marked as **Exhibit 3**, and agrees to comply with the conditions and requirements within the Asbestos Certification.
- c. Lessor agrees to protect, indemnify and save harmless Lessee from and against any and all liabilities, losses, damages, costs, expenses (including, without limitation, reasonable attorney's fees and costs), cause of action, suits, claims, demands or judgments of any nature arising from any injuries to, or the death of any person growing out of, or connected with, the presence of asbestos in the Premises or the Building or any of the Building systems or components serving the Premises.

29. Assignment by Lessor.

- a. Lessee shall not be obligated to recognize any assignment or other transfer of the Lease by Lessor, nor shall Lessee be obligated to pay the Rent or other sums payable to Lessor hereunder, to any assignee or other transferee of the interest of Lessor in the Lease, unless and until such assignment or transfer has been approved, in writing, by Lessee, which approval shall not be unreasonably withheld.
- b. Until such approval is granted, Lessee shall have the right to continue to recognize and treat the assigning Lessor as the "Lessor" for all purposes of the Lease.
- c. Lessor shall provide a written request for approval of assignment or other transfer of the Lease by Lessor to Lessee at least ninety (90) days prior to transfer.
- d. Within thirty (30) days following receipt of Lessor's written notice, Lessee shall advise Lessor in writing of the applications, documents and other information required to enable Lessee to assess and act upon Lessor's request for approval.
- e. Within sixty (60) days following receipt by Lessee of all completed applications, documents and other information required to enable Lessee to assess and act upon Lessor's request for approval, Lessee shall provide written notice of their approval or disapproval of such assignment or other transfer.
- f. In no event, shall Lessee's failure to provide such written notice within the sixty (60) days be deemed to constitute Lessee's approval of such assignment or other transfer.

30. Assignment and Subletting by Lessee.

- a. Lessee shall have the right to assign the Lease or sublet all or any part of the Premises subject to the approval of Lessor, which approval shall not be unreasonably withheld, delayed or conditioned.
- b. Notwithstanding the foregoing, and without requiring Lessor's approval, Lessee shall be permitted to assign the Lease or sublet all or any portions of the Premises to any departments or agencies of the Commonwealth of Pennsylvania.
- c. Lessee will not be released from liability as a result of any assignment or sublease.

- d. Notwithstanding the foregoing, use of the Premises by another Commonwealth agency shall not be deemed a sublease or assignment and shall not require the consent or approval of Lessor.

31. Right to Know Law Requirements.

- a. The *Pennsylvania Right-to-Know Law, 65 P.S. §§ 67.101-3104* ("RTKL") applies to this Lease.
- b. If Lessee needs Lessor's assistance in any matter arising out of the RTKL related to this Lease, it shall notify Lessor using the legal contact information provided in this Lease. Lessor, at any time, may designate a different contact for such purpose upon reasonable prior written notice to Lessee.
- c. Upon written notification from Lessee that it requires Lessor's assistance in responding to a request under the RTKL for information in Lessor's possession, constituting, or alleged to constitute, a public record in accordance with the RTKL ("Requested Information"), Lessor shall:
 - i. Provide Lessee, within ten (10) calendar days after receipt of written notification, access to, and copies of, any document or information in Lessor's possession arising out of this Lease that Lessee reasonably believes is Requested Information and may be a public record under the RTKL; and
 - ii. Provide such other assistance as Lessee may reasonably request, in order to comply with the RTKL with respect to this Lease.
- d. If Lessor considers the Requested Information to include a request for a Trade Secret or Confidential Proprietary Information, as those terms are defined by the RTKL, or other information that the Lessor considers exempt from production under the RTKL, Lessor must notify Lessee and provide, within seven (7) calendar days of receiving the written notification, a written statement signed by a representative of Lessor, explaining why the requested material is exempt from public disclosure under the RTKL.
- e. Lessee will rely upon the written statement from Lessor in denying a RTKL request for the Requested Information unless Lessee determines that the Requested Information is clearly not protected from disclosure under the RTKL. Should Lessee determine that the Requested Information is clearly not exempt from disclosure, Lessor shall provide the Requested Information within five (5) business days of receipt of written notification of Lessee's determination.
- f. If Lessor fails to provide the Requested Information within the time period required by these provisions, Lessor shall indemnify and hold Lessee harmless from any damages, penalties, costs, detriment or harm that Lessee may incur as a result of Lessor's failure, including any statutory damages assessed against Lessee.
- g. Lessee will reimburse Lessor for any costs associated with complying with these provisions only to the extent allowed under the fee schedule established by the Office of Open Records or as otherwise provided by the RTKL if the fee schedule is inapplicable.
- h. Lessor may file a legal challenge to any Lessee decision to release a record to the public with the Office of Open Records, or in the Pennsylvania courts; however, Lessor shall indemnify Lessee for any legal expenses incurred by Lessee as a result of such a challenge and shall hold Lessee harmless from any damages, penalties, costs, detriment or harm that Lessee may incur as a result of Lessor's failure, including any statutory damages assessed against Lessee, regardless of the outcome of such legal challenge. As between the parties, Lessor agrees to waive all rights or remedies that may be available to it as a result of Lessee's disclosure of Requested Information pursuant to the RTKL.
- i. Lessor's duties relating to the RTKL are continuing duties that survive the expiration of this Lease and shall continue as long as Lessor has Requested Information in its possession.

32. Payment of Prevailing Minimum Wages. Lessor and Lessor's contractor(s) must comply with the following conditions, provisions and requirements in the construction of the building, substantial rehabilitation of the building and/or substantial alterations to the Premises:

- a. Lessor and Lessor's contractors shall pay at least the wage rates as determined by the Secretary of the Pennsylvania Department of Labor and Industry and shall comply with the conditions of the *Prevailing Wage Act of August 15, 1961, 43 P.S. § 165-1 et seq.*, and the regulations issued thereto, to assure the full and proper payment of the rates.
- b. Workers in the construction of the building, substantial rehabilitation of the building and/or substantial alterations to the Premises shall be paid at least the general prevailing minimum wage rates as set forth in the prevailing minimum wage predetermination, issued by the Secretary of Labor and Industry, attached hereto and marked as **Exhibit 4**.
- c. These requirements apply to work performed in the construction of the building, substantial rehabilitation of the building and/or substantial alterations to the Premises by Lessor, Lessor's contractor(s) and all subcontractors.
- d. Lessor shall insert in all its contracts for the construction of the building, substantial rehabilitation of the building and/or substantial alterations to the Premises and shall require the contractor(s) to insert in each of its subcontracts the stipulations contained in these provisions.
- e. No workers may be employed in the construction of the building, substantial rehabilitation of the building and/or substantial alterations to the Premises except in accordance with the classifications in the prevailing minimum wage predetermination of the Secretary. If additional or different classifications are necessary, Lessor shall request the Department of General Services to petition the Secretary of Labor and Industry for rates for additional or different classifications.
- f. Workers employed or working in the construction of the building, substantial rehabilitation of the building and/or substantial alterations to the Premises shall be paid unconditionally, regardless of whether a contractual relationship exists or the nature of a contractual relationship which may be alleged to exist between a contractor, subcontractor and worker, at least once a week, without deduction or rebate, on any account, either directly or indirectly except authorized deductions, the full amounts due at the time of payment, computed at the rates applicable to the time worked in the appropriate classification. Nothing in the lease, the *Prevailing Wage Act* or the regulations promulgated pursuant to the Act prohibits the payment of more than the general prevailing minimum wage rates as determined by the Secretary to a worker on a public work.
- g. Lessor shall require its contractor(s) and each subcontractor to post for the entire period of the construction of the building, substantial rehabilitation of the building and/or substantial alterations to the Premises the wage determination decisions of the Secretary, including the effective date of changes thereof, in a prominent and easily accessible place or places at the site of the work and at the places used by them to pay workers their wages. The posted notice of wage rates shall contain the following information:
 - i. The name of project.
 - ii. The name of the Commonwealth agency that will be the tenant in the facility.
 - iii. The crafts and classifications of workers listed in the Secretary's general prevailing minimum wage rate determination for the particular project.
 - iv. The general prevailing minimum wage rates determined for each craft and classification and the effective date of changes.
 - v. A statement advising workers that if they have been paid less than the general prevailing minimum wage rate for their job classification or that the contractor or subcontractor are not complying with the act or this title, they may file a protest in writing with the Secretary of Labor and Industry within 3 months of the date of the occurrence, objecting to the payment to a contractor to the extent of the amount due or to become due to them as wages for work performed on the public work project. A worker paid less than the rate specified in the contract shall have a civil right to action for the difference between the wage paid and the wages stipulated in the contract, which right of action shall be exercised within 6 months from the occurrence of the event creating the right.

- h. Lessor shall require its contractor(s) and each subcontractor to keep an accurate record showing the name, craft or classification, number of hours worked per day and the actual hourly rate of wage paid, including employee benefits, to each worker employed by him in connection with the public work. The record shall include deductions from each worker. The record shall be preserved for 2 years from the date of payment and shall be open at reasonable hours to the inspection of the Department of General Services and the Department of Labor and Industry.
- i. Apprentices shall be limited to numbers in accordance with a bona fide apprenticeship program registered with and approved by The Pennsylvania Apprenticeship and Training Council and only apprentices whose training and employment are in full compliance with *The Apprenticeship and Training Act (43 P.S. §§ 90.1-90.10), approved July 14, 1961*, and the regulations issued thereto shall be employed on the public work project. A worker using the tools of a craft who does not qualify as an apprentice within this Paragraph shall be paid the rate predetermined for journeymen in that particular craft or classification.
- j. Wages shall be paid without deductions except authorized deductions. Employers not parties to a contract requiring contributions for employee benefits which the Secretary of Labor and Industry has determined to be included in the general prevailing minimum wage rate shall pay the monetary equivalent thereof directly to the workers.
- k. Payment of compensation to workers for work performed on public work on a lump sum basis, or a piece work system, or a price certain for the completion of a certain amount of work, or the production of a certain result shall be deemed a violation of the *Prevailing Wage Act* and the Lease, regardless of the average hourly earnings resulting therefrom.
- l. Lessor shall require its contractor(s) and each subcontractor to file a statement each week and a final statement at the conclusion of the work on the contract under oath, and in form satisfactory to the Secretary, certifying that workers have been paid wages in strict conformity with the provisions of the contract as prescribed by this provision or if wages remain unpaid to set forth the amount of wages due and owing to each worker respectively.
- m. The provisions of the *Prevailing Wage Act (43 P.S. §§ 165-1 through 165-17)* and the regulations issued thereto (*34 Pa. Code §§ 9.101 through 9.112*) are incorporated by reference in the Lease.
- n. As used in this Paragraph, "substantial rehabilitation" is the conversion or adaptation of an existing facility into a safe, structurally sound building, by gutting and extensive re-construction, to make the building suitable for use by Lessee.
- o. As used in this Paragraph, "substantial alterations" are those alterations to an existing facility by Lessor in accordance with the specifications, plans, or drawings contained in the Lease or where the final plans, drawings or specifications must be reviewed and approved by Lessee.

33. Accessibility to the Premises by Individuals With Disabilities. For the purpose of these provisions, the term contractor is defined as any person, including, but not limited to, a bidder, offeror, supplier, or grantee, who will furnish or perform or seeks to furnish or perform, goods, supplies, services, construction or other activity, under a purchase order, contract, or grant with the Commonwealth.

During the term of this agreement, the contractor agrees as follows:

1. Pursuant to federal regulations promulgated under the authority of the *Americans with Disabilities Act, 28 C. F. R. § 35.101 et seq.*, the contractor understands and agrees that no individual with a disability shall, on the basis of the disability, be excluded from participation in this agreement or from activities provided for under this agreement. As a condition of accepting and executing this agreement, the contractor agrees to comply with the "*General Prohibitions Against Discrimination*," *28 C. F. R. § 35.130*, and all other regulations promulgated under *Title II of the Americans with Disabilities Act* which are applicable to the benefits, services, programs, and activities provided by the Commonwealth through contracts with outside contractors.
2. The contractor shall be responsible for and agrees to indemnify and hold harmless the Commonwealth from all losses, damages, expenses, claims, demands, suits, and actions brought by any party against the Commonwealth as a result of the contractor's failure to comply with the provisions of this Paragraph.

34. **Contractor Integrity Provisions.** The word “contractor” as used herein shall refer to Lessor. It is essential that those who seek to contract with the Commonwealth observe high standards of honesty and integrity. They must conduct themselves in a manner that fosters public confidence in the integrity of the Commonwealth procurement process.

In furtherance of this policy, Contractor agrees to the following:

- a. Contractor shall maintain the highest standards of honesty and integrity during the performance of this contract and shall take no action in violation of state or federal laws or regulations or any other applicable laws or regulations, or other requirements applicable to Contractor or that govern contracting with the Commonwealth.
- b. Contractor shall establish and implement a written business integrity policy, which includes, at a minimum, the requirements of these provisions as they relate to Contractor employee activity with the Commonwealth and Commonwealth employees, and which is distributed and made known to all Contractor employees.
- c. Contractor, its affiliates, agents and employees shall not influence, or attempt to influence, any Commonwealth employee to breach the standards of ethical conduct for Commonwealth employees set forth in the *Public Official and Employees Ethics Act, 65 Pa.C.S. §§1101 et seq.*; the *State Adverse Interest Act, 71 P.S. §776.1 et seq.*; and the *Governor’s Code of Conduct, Executive Order 1980-18, 4 Pa. Code §7.151 et seq.*, or to breach any other state or federal law or regulation.
- d. Contractor, its affiliates, agents and employees shall not offer, give, or agree or promise to give any gratuity to a Commonwealth official or employee or to any other person at the direction or request of any Commonwealth official or employee.
- e. Contractor, its affiliates, agents and employees shall not offer, give, or agree or promise to give any gratuity to a Commonwealth official or employee or to any other person, the acceptance of which would violate the *Governor’s Code of Conduct, Executive Order 1980-18, 4 Pa. Code §7.151 et seq.* or any statute, regulation, statement of policy, management directive or any other published standard of the Commonwealth.
- f. Contractor, its affiliates, agents and employees shall not, directly or indirectly, offer, confer, or agree to confer any pecuniary benefit on anyone as consideration for the decision, opinion, recommendation, vote, other exercise of discretion, or violation of a known legal duty by any Commonwealth official or employee.
- g. Contractor, its affiliates, agents, employees, or anyone in privity with him or her shall not accept or agree to accept from any person, any gratuity in connection with the performance of work under the contract, except as provided in the contract.
- h. Contractor shall not have a financial interest in any other contractor, subcontractor, or supplier providing services, labor, or material on this project, unless the financial interest is disclosed to the Commonwealth in writing and the Commonwealth consents to Contractor’s financial interest prior to Commonwealth execution of the contract. Contractor shall disclose the financial interest to the Commonwealth at the time of bid or proposal submission, or if no bids or proposals are solicited, no later than Contractor’s submission of the contract signed by Contractor.
- i. Contractor, its affiliates, agents and employees shall not disclose to others any information, documents, reports, data, or records provided to, or prepared by, Contractor under this contract without the prior written approval of the Commonwealth, except as required by the *Pennsylvania Right-to-Know Law, 65 P.S. §§ 67.101-3104*, or other applicable law or as otherwise provided in this contract. Any information, documents, reports, data, or records secured by Contractor from the Commonwealth or a third party in connection with the performance of this contract shall be kept confidential unless disclosure of such information is:
 - i. Approved in writing by the Commonwealth prior to its disclosure; or
 - ii. Directed by a court or other tribunal of competent jurisdiction unless the contract requires prior Commonwealth approval; or

- iii. Required for compliance with federal or state securities laws or the requirements of national securities exchanges; or
 - iv. Necessary for purposes of Contractor's internal assessment and review; or
 - v. Deemed necessary by Contractor in any action to enforce the provisions of this contract or to defend or prosecute claims by or against parties other than the Commonwealth; or
 - vi. Permitted by the valid authorization of a third party to whom the information, documents, reports, data, or records pertain: or
 - vii. Otherwise required by law.
- j. Contractor certifies that neither it nor any of its officers, directors, associates, partners, limited partners or individual owners has not been officially notified of, charged with, or convicted of any of the following and agrees to immediately notify the Commonwealth agency contracting officer in writing if and when it or any officer, director, associate, partner, limited partner or individual owner has been officially notified of, charged with, convicted of, or officially notified of a governmental determination of any of the following:
- i. Commission of embezzlement, theft, forgery, bribery, falsification or destruction of records, making false statements or receiving stolen property.
 - ii. Commission of fraud or a criminal offense or other improper conduct or knowledge of, approval of or acquiescence in such activities by Contractor or any affiliate, officer, director, associate, partner, limited partner, individual owner, or employee or other individual or entity associated with:
 - (i) obtaining;
 - (ii) attempting to obtain; or
 - (iii) performing a public contract or subcontract.

Contractor's acceptance of the benefits derived from the conduct shall be deemed evidence of such knowledge, approval or acquiescence.

- iii. Violation of federal or state antitrust statutes.
- iv. Violation of any federal or state law regulating campaign contributions.
- v. Violation of any federal or state environmental law.
- vi. Violation of any federal or state law regulating hours of labor, minimum wage standards or prevailing wage standards; discrimination in wages; or child labor violations.
- vii. Violation of the *Act of June 2, 1915 (P.L. 736, No. 338)*, known as the *Workers' Compensation Act, 77 P.S. 1 et seq.*
- viii. Violation of any federal or state law prohibiting discrimination in employment.
- ix. Debarment by any agency or department of the federal government or by any other state.
- x. Any other crime involving moral turpitude or business honesty or integrity.

Contractor acknowledges that the Commonwealth may, in its sole discretion, terminate the contract for cause upon such notification or when the Commonwealth otherwise learns that Contractor has been officially notified, charged, or convicted.

- k. If this contract was awarded to Contractor on a non-bid basis, Contractor must, (as required by *Section 1641 of the Pennsylvania Election Code*) file a report of political contributions with the Secretary of the Commonwealth on or before February 15 of the next calendar year. The report must include an itemized list of all political contributions known to Contractor by virtue of the knowledge

possessed by every officer, director, associate, partner, limited partner, or individual owner that has been made by:

- i. Any officer, director, associate, partner, limited partner, individual owner or members of the immediate family when the contributions exceed an aggregate of one thousand dollars (\$1,000) by any individual during the preceding year; or
- ii. Any employee or members of his immediate family whose political contribution exceeded one thousand dollars (\$1,000) during the preceding year.

To obtain a copy of the reporting form, Contractor shall contact the Bureau of Commissions, Elections and Legislation, Division of Campaign Finance and Lobbying Disclosure, Room 210, North Office Building, Harrisburg, PA 17120.

- l. Contractor shall comply with requirements of the *Lobbying Disclosure Act, 65 Pa.C.S. § 13A01 et seq.*, and the regulations promulgated pursuant to that law. Contractor employee activities prior to or outside of formal Commonwealth procurement communication protocol are considered lobbying and subjects the Contractor employees to the registration and reporting requirements of the law. Actions by outside lobbyists on Contractor's behalf, no matter the procurement stage, are not exempt and must be reported.
- m. When Contractor has reason to believe that any breach of ethical standards as set forth in law, the Governor's Code of Conduct, or in these provisions has occurred or may occur, including but not limited to contact by a Commonwealth officer or employee which, if acted upon, would violate such ethical standards, Contractor shall immediately notify the Commonwealth contracting officer or Commonwealth Inspector General in writing.
- n. Contractor, by submission of its bid or proposal and/or execution of this contract and by the submission of any bills, invoices or requests for payment pursuant to the contract, certifies and represents that it has not violated any of these contractor integrity provisions in connection with the submission of the bid or proposal, during any contract negotiations or during the term of the contract.
- o. Contractor shall cooperate with the Office of Inspector General in its investigation of any alleged Commonwealth employee breach of ethical standards and any alleged Contractor non-compliance with these provisions. Contractor agrees to make identified Contractor employees available for interviews at reasonable times and places. Contractor, upon the inquiry or request of the Office of Inspector General, shall provide, or if appropriate, make promptly available for inspection or copying, any information of any type or form deemed relevant by the Inspector General to Contractor's integrity and compliance with these provisions. Such information may include, but shall not be limited to, Contractor's business or financial records, documents or files of any type or form that refers to or concern this contract.
- p. For violation of any of these Contractor Integrity Provisions, the Commonwealth may terminate this and any other contract with Contractor, claim liquidated damages in an amount equal to the value of anything received in breach of these provisions, claim damages for all additional costs and expenses incurred in obtaining another contractor to complete performance under this contract, and debar and suspend Contractor from doing business with the Commonwealth. These rights and remedies are cumulative, and the use or non-use of any one shall not preclude the use of all or any other. These rights and remedies are in addition to those the Commonwealth may have under law, statute, regulation, or otherwise.
- q. For purposes of these Contractor Integrity Provisions, the following terms shall have the meanings found in this Paragraph.
 - i. "Confidential information" means information that a) is not already in the public domain; b) is not available to the public upon request; c) is not or does not become generally known to Contractor from a third party without an obligation to maintain its confidentiality; d) has not become generally known to the public through an act or omission of Contractor; or e) has not been independently developed by Contractor without the use of confidential information of the Commonwealth.

- ii. "Consent" means written permission signed by a duly authorized officer or employee of the Commonwealth, provided that where the material facts have been disclosed, in writing, by pre-qualification, bid, proposal, or contractual terms, the Commonwealth shall be deemed to have consented by virtue of execution of this contract.
- iii. "Contractor" means the individual or entity that has entered into this contract with the Commonwealth, including those directors, officers, partners, managers, and owners having more than a five percent interest in Contractor.
- iv. "Financial interest" means:
 - (i) Ownership of more than a five percent interest in any business; or
 - (ii) Holding a position as an officer, director, trustee, partner, employee, or holding any position of management.
- xi. "Gratuity" means tendering, giving or providing anything of more than nominal monetary value including, but not limited to, cash, travel, entertainment, gifts, meals, lodging, loans, subscriptions, advances, deposits of money, services, employment, or contracts of any kind. The exceptions set forth in the *Governor's Code of Conduct, Executive Order 1980-18*, the *4 Pa. Code §7.153(b)*, shall apply.
- xii. "Immediate family" means a spouse and any unemancipated child.
- xiii. "Non-bid basis" means a contract awarded or executed by the Commonwealth with Contractor without seeking bids or proposals from any other potential bidder or offeror.
- xiv. "Political contribution" means any payment, gift, subscription, assessment, contract, payment for services, dues, loan, forbearance, advance or deposit of money or any valuable thing, to a candidate for public office or to a political committee, including but not limited to a political action committee, made for the purpose of influencing any election in the Commonwealth of Pennsylvania or for paying debts incurred by or for a candidate or committee before or after any election.

34. **Contractor Responsibility Provisions.** For the purpose of these provisions, the term contractor is defined as any person, including, but not limited to, a bidder, offeror, loan recipient, grantee or lessor, who has furnished or performed or seeks to furnish or perform, goods, supplies, services, leased space, construction or other activity, under a contract, grant, lease, purchase order or reimbursement agreement with the Commonwealth. The term contractor includes a permittee, licensee, or any agency, political subdivision, instrumentality, public authority, or other public entity in the Commonwealth. It shall be understood that the word "Contractor" as used herein shall refer to Lessor.

- a. The Contractor certifies, in writing, for itself and its subcontractors required to be disclosed or approved by the Commonwealth, that as of the date of its execution of this Bid/Contract, that neither the Contractor, nor any such subcontractors, are under suspension or debarment by the Commonwealth or any governmental entity, instrumentality, or authority and, if the Contractor cannot so certify, then it agrees to submit, along with the Bid/Contract, a written explanation of why such certification cannot be made.
- b. The Contractor also certifies, in writing, that as of the date of its execution of this Bid/Contract it has no tax liabilities or other Commonwealth obligations, or has filed a timely administrative or judicial appeal if such liabilities or obligations exist, or is subject to a duly approved deferred payment plan if such liabilities exist.
- c. The Contractor's obligations pursuant to these provisions are ongoing from and after the effective date of the Contract through the termination date thereof. Accordingly, the Contractor shall have an obligation to inform the Commonwealth if, at any time during the term of the Contract, it becomes delinquent in the payment of taxes, or other Commonwealth obligations, or if it or, to the best knowledge of the Contractor, any of its subcontractors are suspended or debarred by the Commonwealth, the federal government, or any other state or governmental entity. Such notification shall be made within 15 days of the date of suspension or debarment.

- d. The failure of the Contractor to notify the Commonwealth of its suspension or debarment by the Commonwealth, any other state, or the federal government shall constitute an event of default of the Contract with the Commonwealth.
- e. The Contractor agrees to reimburse the Commonwealth for the reasonable costs of investigation incurred by the Office of State Inspector General for investigations of the Contractor's compliance with the terms of this or any other agreement between the Contractor and the Commonwealth that results in the suspension or debarment of the contractor. Such costs shall include, but shall not be limited to, salaries of investigators, including overtime; travel and lodging expenses; and expert witness and documentary fees. The Contractor shall not be responsible for investigative costs for investigations that do not result in the Contractor's suspension or debarment.
- f. The Contractor may obtain current list of suspended and debarred Commonwealth contractors by either searching the Internet at <http://www.dgs.state.pa.us/debarment.htm> or contacting the:

Department of General Services
Office of Chief Counsel
603 North Office Building
Harrisburg, PA 17125
Telephone No: (717) 783-6472
FAX No: (717) 787-9138

35. **Offset Provisions.** The word "Contractor" as used herein shall refer to Lessor. The Contractor agrees that the Commonwealth of Pennsylvania (the "Commonwealth") may set off the amount of any state tax liability or other obligation of the Contractor or its subsidiaries to the Commonwealth against any payments due the Contractor under any contract with the Commonwealth.
36. **Nondiscrimination/Sexual Harassment Clause.** The word "Contractor" as used herein shall refer to Lessor. The Contractor agrees:
- a. In the hiring of any employee(s) for the performance of work, or any other activity required under the contract, or any subcontract, subcontract, the Contractor, subcontractor, or any person acting on behalf of the Contractor or subcontractor shall not, by reason of gender, race, creed, or color, discriminate against any citizen of this Commonwealth who is qualified and available to perform the work to which the employment relates.
 - b. Neither the Contractor nor any subcontractor nor any person on their behalf shall in any manner discriminate against or intimidate any employee involved in the performance of work, or any other activity required under the contract on account of gender, race, creed, or color.
 - c. The Contractor and any subcontractors shall establish and maintain a written sexual harassment policy and shall inform their employees of the policy. The policy must contain a notice that sexual harassment will not be tolerated and employees who practice it will be disciplined.
 - d. The Contractor and any subcontractors shall not discriminate by reason of gender, race, creed, or color against any subcontractor or supplier who is qualified to perform the work to which the contracts relates.
 - e. The Contractor and each subcontractor shall furnish all necessary employment documents and records and permit access to their books, records, and accounts by the contracting agency and the Bureau of Small Business Opportunities ("BSBO") for purpose of ascertaining compliance with provisions of this Nondiscrimination/Sexual Harassment Clause. If the Contractor or any subcontractor does not possess documents or records reflecting the necessary information requested, the Contractor or subcontractor shall furnish such information on reporting forms supplied by the contracting agency or the BSBO.
 - f. The Contractor shall include the provisions of this Nondiscrimination/Sexual Harassment Clause in every subcontract so that those provisions applicable to subcontractors will be binding upon each subcontractor.
 - g. The Commonwealth may cancel or terminate the contract and all money due or to become due under the contract may be forfeited for a violation of the terms and conditions of this

Nondiscrimination/Sexual Harassment Clause. In addition, the agency may proceed with debarment or suspension and may place Contractor in the Contractor Responsibility File.

37. **Notice.** Any notice or demand from Lessee to Lessor or from Lessor to Lessee shall be in writing and shall be delivered by hand or by deposit in United States mail, postage prepaid, via registered or certified mail. If the Notice is to the Lessor, it should be placed in an envelope addressed to the attention of the Lessor Contact identified on the Lease Cover Sheet. If the Notice is to the Lessee, it should be placed in an envelope addressed to the attention of:

Director
Bureau of Real Estate
Department of General Services
503 North Office Building
Harrisburg, Pennsylvania 17125

37. **Events of Default.** Any one or more of the following events shall constitute an "Event of Default":

- a. Failure of Lessor to provide the services as stipulated in this Lease without disruption or interruption.
- b. Failure of Lessor to maintain the Premises in a safe and tenantable condition.
- c. Failure of Lessor to provide peaceful and uninterrupted possession of the Premises by Lessee.
- d. Failure of Lessor to perform or observe any obligations set forth in this Lease.
- e. Failure of Lessor to notify Lessee of Lease Assignments prior to receiving Lessee's written approval to assign the Lease.
- f. Failure of Lessor to perform or observe any of the other covenants, terms or conditions contained in this Lease within thirty (30) days after written notice by Lessee.

38. **Remedies of Lessee.** Upon the occurrence and continuance of an Event of Default by Lessor, Lessee may, after giving Lessor thirty (30) days' written notice, except as modified as forth herein, exercise one or more of the following remedies:

- a. If any Event of Default by Lessor results in a material disruption in Lessee's business operations at the Premises of longer than twenty four (24) hours and Lessee notified Lessor of the material disruption in Lessee's business operation with a request to cure within a shorter time period of thirty (30) days as to ensure that Lessee does not continue to experience disruption in their business operations and Lessor fails to cure within any such shorter time period stated in said notice, then Lessee may cure, with written notice to the Lessor, the Event of Default, which is a material disruption in Lessee's business operations, at Lessor's sole cost and expense.
 - i. Lessor shall reimburse Lessee for their reasonable costs and expenses, including but not limited to costs incurred due to a temporary move of Lessee, in connection with Lessee curing the Event of Default together with interest on the amount of such costs and expenses, including but not limited to costs incurred for any and all temporary relocation(s), as a result of the Event of Default, of Lessee, at a rate of ten percent (10%) per annum from the date such costs and expenses were incurred.
 - ii. Such reimbursement shall be made within ten (10) days after Lessor receives an invoice from Lessee detailing the costs and expenses of the cure.
 - iii. If Lessor fails to pay the Lessee the full amount, as evidenced in the invoice from Lessee, within ten (10) days after receipt of the invoice, then Lessee shall have the right to set off the full amount due to Lessee against the Rent.
 - iv. Lessor shall continue to be liable to Lessee for any amounts Lessee elects not to offset against Rent.

- b. If an Event of Default poses a risk of material injury or damage to persons or property, and a cure is reasonably necessary to prevent material injury or damage to persons or property, and Lessee so notifies Lessor of this risk and the necessity to cure within a shorter time period of thirty (30) days, and Lessor fails to commence its cure within any such shorter time period stated in said notice to prevent material injury or damage, then Lessee may, after written notice to Lessor, cure the Event of Default which poses a risk of material injury or damage to persons or property.
 - i. Lessor shall reimburse Lessee for their reasonable costs and expenses, including but not limited to costs incurred due to a temporary move of Lessee, in connection with Lessee curing the Event of Default together with interest on the amount of such costs and expenses, including but not limited to costs incurred for any and all temporary relocation(s), as a result of the Event of Default, of Lessee, at a rate of ten percent (10%) per annum from the date such costs and expenses were incurred.
 - ii. Such reimbursement shall be made within ten (10) days after Lessor receives an invoice from Lessee detailing the costs and expenses of the cure.
 - iii. If Lessor fails to pay the Lessee the full amount, as evidenced in the invoice from Lessee, within ten (10) days after receipt of the invoice, then Lessee shall have the right to set off the full amount due to Lessee against the Rent.
 - iv. Lessor shall continue to be liable to Lessee for any amounts Lessee elects not to offset against Rent.
 - c. Lessee shall not be liable to Lessor for the manner in which Lessee performs Lessor's obligations under this Paragraph, and Lessor releases Lessee of any liability of any nature related to such performance.
 - d. Lessee's performance of a Lessor obligation under this Paragraph shall not relieve Lessor from thereafter performing that obligation.
 - e. Terminate this Lease and the tenancy created hereby.
 - f. Abate payment of Rent as long as the Event of Default remains in effect. After corrective action has been completed by Lessor, Lessee shall pay Lessor the withheld Rent less any costs and expenses, including but not limited to, costs incurred for any and all temporary relocation(s) of Lessee, as a result of the Event of Default suffered by Lessee.
 - g. The thirty (30) day notice requirement imposed by Lessee in this Paragraph does not apply where the Event of Default results in Lessee's vacating the Premises. In such an event, the Lessor's thirty (30) day period to cure begins immediately upon the occurrence of the Event of Default notwithstanding that Lessor's written default notice may be sent subsequent to the occurrence of the Event of Default.
 - h. Notwithstanding the last sentence of this Paragraph, Lessee, in its sole discretion, may immediately and permanently abate Rent for the period Lessee is constructively evicted from the Premises.
 - i. Notwithstanding any other provision of this Lease, Lessee in its sole discretion may terminate this Lease and the tenancy created hereby in the event there are three or more Events of Default within any three-hundred sixty-five (365) day period, regardless of whether Lessor cures the defaults in accordance with this Paragraph.
 - j. The remedies of Lessee set forth in this Paragraph shall be in addition to all other remedies available at law or equity to Lessee for any default by Lessor under this Lease.
39. **No Waiver of Rights.** The failure by Lessee to require performance of any provision of this Lease shall not affect Lessee's right to require performance at any time thereafter. Further, a waiver of any breach or default of this Lease shall not constitute a waiver of any subsequent breach or default or a waiver of the provision itself.

40. **Disputes.**

- a. In the event of a controversy or claim arising from the Lease,
 - i. Lessor shall, within six (6) months after the cause of action accrues, file a written claim with the Director of the Bureau of Real Estate, Department of General Services, for a determination. The claim shall state all grounds upon which Lessor asserts a dispute exists.
 - ii. If Lessor fails to file a claim or files an untimely claim, Lessor acknowledges and agrees that they have waived their right to assert a claim in any forum.
- b. At the time the claim is filed, or within sixty (60) days thereafter, either party may request mediation through the Commonwealth Office of General Counsel Dispute Resolution Program.
 - i. If Lessor or the Director of the Bureau of Real Estate requests mediation and the other party agrees, the Director of the Bureau of Real Estate shall promptly make arrangements for mediation.
 - ii. Mediation shall be scheduled so as to not delay the issuance of the final determination beyond the required one hundred twenty (120) days after receipt of the claim if mediation is unsuccessful.
- c. If mediation is not agreed to or if a resolution is not reached through mediation, the Director of the Bureau of Real Estate shall review any timely-filed claim and issue a final determination, in writing, regarding the claim.
- d. The final determination shall be issued within one hundred twenty (120) days of the receipt of the claim, unless extended by consent of Lessee and the Lessor. The Director of the Bureau of Real Estate shall send his/her written determination to Lessor.
 - i. If the Director of the Bureau of Real Estate fails to issue a final determination within one hundred twenty (120) days (unless extended by consent of the parties), the claim shall be deemed denied.
 - ii. The determination of the Director of the Bureau of Real Estate shall be the final order of the Department of General Services.
- e. Within fifteen (15) days of the mailing date of the determination denying a claim, or within one hundred thirty five (135) days of filing a claim, if no extension is agreed to by the parties, whichever occurs first, Lessor may file a statement of claim with the Commonwealth Board of Claims.
- f. Pending a final judicial resolution of a controversy or claim, Lessor shall proceed diligently with the performance of this Lease in a manner consistent with the determination of the Director of the Bureau of Real Estate.
- g. Notwithstanding anything herein to the contrary, Lessee expressly reserves its rights to file any claim against Lessor in any forum of their choice including, but not limited to, the Commonwealth Board of Claims, Commonwealth Court, Dauphin County, or any other county court, and the U.S. District Court for the Middle District of Pennsylvania.

41. **Attachments and Exhibits Part of Lease.** Included in and made a part of this Lease, with the same force and effect as though fully set forth in this Lease are the following attached Attachments and Exhibits:

ATTACHMENTS:

Attachment A – Lease Standard Terms and Conditions

Exhibit 1 – Acceptance of Leased Premises Inspection Report

Exhibit 2 – Consent Form

Exhibit 3 -- Asbestos Certification

Exhibit 4 -- Prevailing Minimum Wages

Attachment B –Commonwealth of Pennsylvania Standard Building Specifications

Attachment C –Commonwealth of Pennsylvania Using Agency Building Specifications

42. **Modifications to the Lease.** This Lease may not be modified orally and supersedes all prior agreements and understandings, both written and oral, between the parties with respect to this Lease. Any and all modifications to the Lease must be done by Lease Amendment that is signed by both parties and approved by the Board of Commissioners of Public Grounds and Buildings, the Secretary of the Department of General Services, or via Consent Form.
43. **Interpretation.** This Lease shall be construed and interpreted in accordance with the laws of the Commonwealth of Pennsylvania.
44. **Review of Lease.** The parties acknowledge that each party and its respective counsel have reviewed this Lease and that no rule of construction to the effect that any ambiguities are to be resolved against the drafting party shall be employed in the interpretation of this Lease or any amendment or Exhibits hereto.
45. **Execution.** Lessor agrees and acknowledges that this Lease is subject to final execution by the Secretary of the Department of General Services and approval by the Board of Commissioners of Public Grounds and Buildings.
46. **Time is of the Essence.** Time is of the essence of all provisions of the Lease, including all Notice Provisions, to be performed by or on behalf of Lessor and Lessee.
47. **Binding Successors and Assigns.** All rights and liabilities herein given to, or imposed upon, the respective parties hereto shall extend to and bind the several respective successors and permitted assigns of the parties.
48. **Survival.** The expiration of the Term, whether by lapse of time or otherwise, shall not relieve either party of any obligations which accrued prior to, or which may continue to accrue, after the expiration of or early termination of this Lease.
49. **Conflict Between Lease Terms and Conditions and Specifications.** To the extent that there are any conflicts among the Lease Cover Sheet, these **Attachment A** Lease Standard Terms and Conditions, the Commonwealth of Pennsylvania Standard Building Specifications set forth in **Attachment B**, and/or the Commonwealth of Pennsylvania Using Agency Building Specifications set forth in **Attachment C**, Lessor shall maintain/construct the Premises in accordance with the most stringent standard.
50. **Integration.** This Lease, including all referenced Attachments and Exhibits, constitutes the entire agreement between the parties. No agent, representative, employee, or officer of Lessor or Lessee has the authority to make, or has made, any statement, agreement, or representation, oral or written, in connection with this Lease, which in any way can be deemed to modify, add to, or detract from, or otherwise change or alter its terms and conditions. No negotiations between the parties, nor any custom or usage, shall be permitted to modify or contradict any of the terms and conditions of this Lease. No modifications, alterations, changes, or waiver to this Lease or any of its terms shall be valid or binding unless accomplished by a written amendment or Consent Form signed by both parties, consistent with Paragraph 41, "Attachments and Exhibits Part of Lease" and Paragraph 42, "Modifications to the Lease".

EXHIBIT 1

Acceptance of Leased Premises and/or Renovations Inspection
Report (GSRR-42-N (08-13))

ACCEPTANCE OF LEASED PREMISES AND/OR RENOVATIONS
INSPECTION REPORT
EXHIBIT "1"

LESSOR: _____
(NAME)

(STREET) (CITY) (COUNTY)

LOCATION: _____
(STREET) (CITY) (COUNTY)

USING AGENCY: _____
(DEPARTMENT) (BUREAU)

This is to certify that I have visually inspected the above premises on _____ (DATE)
and find that the premises are built and/or renovated in accordance with the requirements of
Lease _____,
(LEASE #)

with the exception of the following items:

1. _____
2. _____
3. _____
4. _____
5. _____
6. _____

(Additional items on attached sheet, if necessary)

The _____ (USING AGENCY) hereby accepts the above premises for occupancy
effective _____ (ACCEPTANCE DATE) and approves the _____ New Construction _____ Renovations

excepting the above items numbered _____

Further, _____ (USING AGENCY) agrees that _____ (ACCEPTANCE DATE)

is to be the effective date of occupancy; that the rental for the above mentioned property shall commence on that
date, that the lease term, upon the execution of this document by all parties, shall extend for _____ years
from the acceptance date; with any option terms provided for in the lease being adjusted accordingly.

(USING AGENCY'S REPRESENTATIVE)

(TITLE)

(USING AGENCY)

I understand and agree to the foregoing and I certify, as lessor of the above referenced premises, that
completion of the excepted items as stated herein shall be no later than _____. I also
acknowledge _____

and agree that, should I fail to complete any of those items within the above time frame, then the (USING
AGENCY) _____ may at its discretion withhold rental payments.

I hereby agree to the adjustment in the lease and option terms described above.

(LESSOR)

Copy to DGS _____
DATE

Copy to Treasury _____

EXHIBIT 2

Leasehold Improvement Consent Form

EXHIBIT "2"
CONSENT FORM

SPC NO.

LEASE #

LESSOR:

LESSEE:

Property
Address:

The LESSOR of the above-referenced property hereby consents and otherwise authorizes the LESSEE to make leasehold improvements to the leased premises as per attached plans and specifications.

The total cost of the leasehold improvements is estimated at \$ _____ and this cost will be borne in full by the LESSEE.

The LESSOR understands and agrees that the items installed by LESSEE shall remain the property of the Commonwealth and non-fixture items may be removed by the LESSEE provided that the leased premises are restored to their original condition, ordinary wear and tear excepted.

The LESSOR, through its duly authorized officers, hereby executes this consent form this _____ day of _____, 20____. Individual and/or Partnership

Witness

Lessor

Corporation

Lessor - Corporate Name

Secretary/Treasurer

President/Vice President

"FOR DGS USE ONLY"

Reviewed By: _____ Date

- Approved
 - Disapproved
- (See Attached)

EXHIBIT 3

Asbestos Certification

ASBESTOS CERTIFICATE
Exhibit "3"

1. LESSOR certifies that an asbestos survey has been completed relative to the entire building in which the space is located in accordance with the following criteria:

a. Building(s) must be inspected by PAL&I-certified inspector(s), each with a minimum of one (1) year experience in conducting building inspections for asbestos-containing materials (ACM).

b. Samples must be collected and analyzed in numbers no less stringent than AHERA guidelines.

c. Sample analysis must be performed by laboratory(ies) accredited under the NVLAP program for asbestos bulk sample analysis.

d. All suspect materials must be analyzed for asbestos, except for the following:

- 1. Roofing materials**
- 2. Undamaged firedoors**
- 3. Exterior siding**

e. Suspect materials not analyzed must be reported as "assumed-ACM".

f. Physical and hazard assessments of all ACM and assumed-ACM must be performed by PAL&I-certified management planner(s), each with a minimum of one year experience in preparing management plans for ACM in buildings.

Two complete copies of the management plan, including a completed Table C-1, must be submitted to LESSEE for review prior to the issuance of a LEASE. The management plan must include copies of all bulk sample analysis results, floor plans or diagrams indicating the location of all ACM and assumed-ACM, and explicit recommendations for each area of ACM found or assumed. Table C-1 must list all materials tested or assumed, regardless of the results. For materials verified by laboratory analysis to be non-ACM, only the first four (4) columns of Table C-1 must be completed.

2. LESSOR agrees that any and all recommendations made by the professional preparing the above management plan to repair, remove, encapsulate, or otherwise abate any or all ACM or assumed-ACM in the building(s) will be completed prior to occupancy by LESSEE. As a minimum requirement, all ACM or assumed-ACM with any degree of

damage must be restored to an undamaged condition prior to occupancy of the PREMISES by LESSEE. LESSEE will not be responsible for any expenses incurred in complying with the recommended actions, or for LEASE payments prior to occupancy. This work must be completed in accordance with the following criteria:

a. LESSOR will notify LESSEE of all asbestos-related work, in writing, at least twenty (20) days prior to commencement of such work. When responding to emergency situation, notification to the LESSEE must occur as soon as possible, but no later than 12 hours after commencement of the work.

b. Abatement contractor must be PAL&I-certified as a contractor and have a minimum of two (2) years experience in performing asbestos abatement work.

c. Workers must be PAL&I-certified as asbestos abatement workers.

d. Workers must be supervised by a PAL&I-certified abatement supervisor with a minimum of one (1) year experience in asbestos abatement.

e. The services of an independent consulting firm must be retained during the course of abatement to monitor the contractor's performance, conduct air monitoring both inside and outside of critical barriers each day abatement is conducted, and conduct clearance testing.

f. Daily air monitoring will consist of collecting a minimum of two (2) samples inside, and two (2) outside, each individual work area. Sample volume must exceed 1800 liters and analysis should be by phase contrast microscopy using NIOSH 7400 performed by an AIHA-accredited laboratory. Analysis results greater than or equal to .01 fibers per cubic centimeter for samples collected outside of the critical barriers will require prompt action on the part of the LESSOR, at the LESSOR'S sole cost, to protect LESSEE'S employees health and safety.

g. For clearance testing of projects involving the disturbance of a quantity of ACM or assumed-ACM less than or equal to 160 square feet of 260 linear feet, five (5) samples must be collected and analyzed by phase contrast microscopy using NIOSH 7400 performed by an AIHA-accredited laboratory. The volume of each sample must exceed 1800 liters. Analysis results greater than or equal to .01 fibers per cubic centimeter for any of the samples will result in failure of the testing, and will require recleaning until all five (5) sample results are less than .01 fibers per cubic centimeter.

h. For clearance testing of projects involving the disturbance of a quantity of ACM or assumed-ACM greater than 160 square feet of 260 linear feet, the guidelines of 40 CFR Part 763, Subpart E, Appendix A, Section IV (Mandatory Interpretation of Transmission Electron Microscopy Results to Determine Completion of Response Actions) shall apply.

i. Verbal results of clearance monitoring following abatement must be provided to LESSEE prior to removal of primary barriers. In addition, copies of all air monitoring results and hygienist's reports must be delivered to LESSEE within thirty (30) days following completion of any abatement action.

This work must be completed, and written certification by the LESSOR'S consultant provided, within thirty (30) days prior to the date LESSEE would otherwise take possession of the PREMISES. LESSEE may elect to terminate this LEASE by written notice to the LESSOR if these requirements are not met.

3. LESSOR further agrees that during the period of time that the building(s) contains damaged ACM or damaged assumed-ACM in any form, air monitoring will be conducted at approximately one (1) month intervals, at the LESSOR'S sole expense. Air monitoring shall begin within seventy two (72) hours following discovery by, or notification to, the LESSOR that damaged ACM or damaged assumed-ACM exists. One sample for each 10,000 square feet of floor area must be collected, with a minimum of three (3) samples collected and analyzed per air monitoring interval. Sample volume must exceed 1800 liters and analysis should be by phase contrast microscopy using NIOSH 7400 or equivalent performed by an AIHA-accredited laboratory. Verbal results of air monitoring must be provided to LESSEE within forty eight (48) hours of the laboratory's notification to the LESSOR, with copies of the written laboratory report to follow within fifteen (15) days. Analysis results greater than or equal to .01 fibers per cubic centimeter in any sample will require action, within forty eight (48) hours, on the part of the LESSOR and at the LESSOR'S sole cost, to protect LESSEE'S employees by undertaking during non-working hours the following:

a. Repair all damaged ACM and damaged assumed-ACM, and remove all debris suspected of containing asbestos.

b. Remove and replace damaged ACM and damaged assumed-ACM with other appropriate building materials and restore the building to a safe condition, or

c. Encapsulate, enclose, encase, or other appropriate containment method on the damaged ACM and damaged assumed-ACM.

This work must be completed in compliance with the criteria listed in Section 2. In addition to the LESSOR'S testing responsibility, LESSEE retains the right to collect any samples and conduct any testing.

Regardless of air monitoring results, all damaged ACM and damaged assumed-ACM must be repaired to abated within sixty (60) days from the date of discovery by, or notification to, the LESSOR. If the required repairs or abatement is not completed within this time period, LESSEE may either terminate this LEASE immediately without prior notice, or make any changes, repairs, and alterations LESSEE deems necessary to protect the health and safety of its employees.

4. LESSEE shall be entitled to claim from LESSOR all consequential damages arising out of LESSOR'S breach of warranty and representations contained in this Exhibit. Furthermore, if LESSEE or its agents repair or abate ACM and assumed-ACM pursuant to this Exhibit, LESSOR shall reimburse LESSEE, within fifteen (15) days, for all costs and expenses associated therewith, including, but not limited to costs of repair, abatement and disposal of ACM and assumed-ACM, costs of restoration, costs of air quality and materials testing and analysis, relocation and incremental rental expenses, and related fees of consultants and experts.

LESSOR agrees to abide by all applicable Federal, State, and Local regulations. LESSOR further agrees to protect, indemnify and save harmless LESSEE from and against any and all liabilities, losses, damages, costs, expenses, causes of action, suits, claims, demands or judgments of any nature arising from any injuries to, or death of any person growing out of or connected with the presence of asbestos in the demised PREMISES.

EXHIBIT 4

Prevailing Minimum Wages

A note to all proposers:

In order to view the current prevailing wages for each craft or classification of workers needed to perform the contract(s) for the construction of or renovations to the leased facility for the locality where the facility will be constructed or renovated, go to:

http://www.dli.state.pa.us/landi/li_apps/requestPW.asp and request the prevailing wages.

Proposals must include a statement indicating whether or not the rent is based upon the requirement to pay prevailing wages.

APPENDIX B
COMMONWEALTH OF PENNSYLVANIA
REQUIRED DOCUMENTS

1. GSRE-19 Proposal to Lease Space to the Commonwealth
2. GSRE-6 Lessor Identity Disclosure (*see attached instructions*)
3. GSRE-47 Agency Agreement/Limited Agent Authority
4. GSRE-42M Contractor Responsibility Certification
5. GSRE-54 Notice – Bureau of Real Estate is Sole Agent for the Commonwealth
6. GSRE-63 Acknowledgment/Useable Area Definition
7. GSRE-64 Consent to Release or Obtain Information and Contact Professional References (*see attached instructions*)

Forms listed above are available electronically at the link below

<http://www.portal.state.pa.us/portal/server.pt?open=512&objID=1346&&SortOrder=100&level=2&parentid=1231&css=L2&mode=2&cached=true>

8. Prevailing Wage Pre-determination from the Department of Labor and Industry (*go to http://www.dli.state.pa.us/landi/li_apps/requestPW.asp and request the prevailing wages. See attached instructions and Page 6 of this SFP for additional information*)

Commonwealth of Pennsylvania

Department of General Services

Bureau of Real Estate

INSTRUCTIONS FOR LESSOR IDENTITY DISCLOSURE AND CONSENT TO RELEASE OR OBTAIN INFORMATION AND CONTACT PROFESSIONAL REFERENCES

Who Must Fill Out Lessor Identity Disclosure and Consent to Release...

- The Corporation
- Individuals owning 30 percent or more of a Corporation or Limited Liability Company
- Partnership owning 30 percent or more of the Partnership
- Limited Liability Partnership owning 30 percent or more of the Partnership
- Sole Proprietor/Co-Owner
- Authority
- Borough, City, Trust or other entity

How Should You Complete Both Forms

- Type or legibly print your EIN, Name and Address in spaces provided
- A separate Consent to Release form must be completed for every corporation/individual that is listed on the Lessor Identity Disclosure form.
- There are two Attachments 1 (please return one and retain the other for your records)
- Return Attachment 2

Questions

- Contact your Real Estate Coordinator at (717) 787-4394

How to submit information for a Prevailing Wage Determination

1. On the internet go to the PA Department of Labor and Industry Homepage.

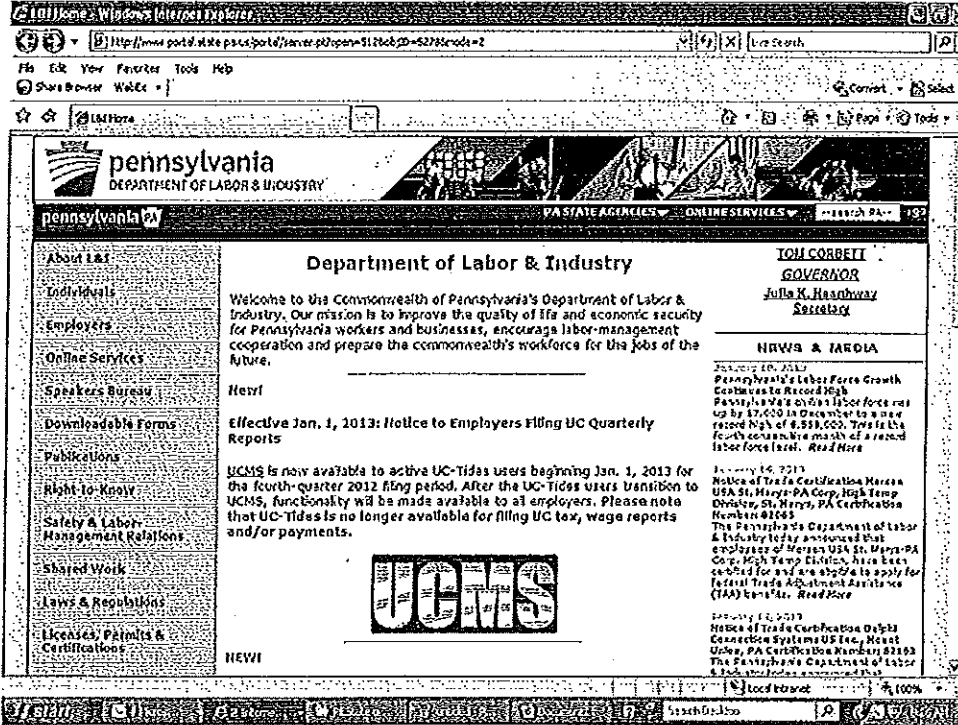

2. Scroll down and select "Labor Law Compliance".

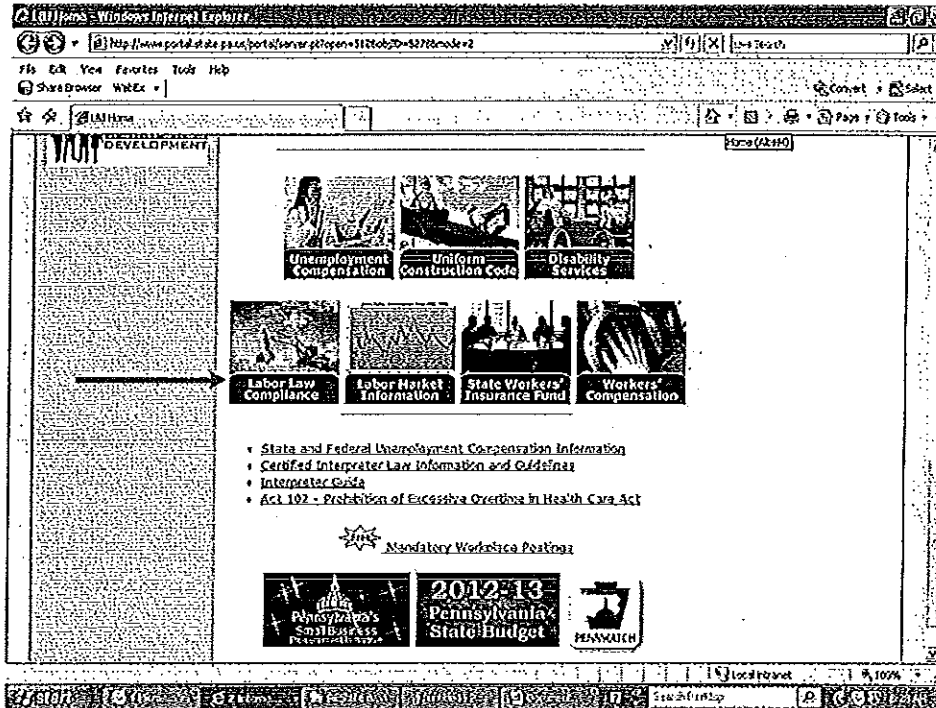

3. Select Prevailing Wage Act

http://www.portal.state.pa.us/portal/server.pt?community=labo...
 File Edit View Favorites Tools Help
 Share Browser WebEx
 Labor Law Compliance
 L&I Home
 Safety and Labor-Management Relations
 Industrial Board
 Labor Law Compliance
 Apprenticeship and Training
 Administration of Equal Pay Law
 Wage Payment
 Industrial Homework
 Mandatory Workplace Postings
 Medical Fee Act
 Overtime Rules in Pennsylvania
 Personnel File Inspection
 Seasonal Farm Labor
 Safety and Labor-Management Relations
Labor Law Compliance
 • Act 22: Construction Workplace Misclassification Act
 • Act 102: Prohibition of Excessive Overtimes in Health Care
 • Apprenticeship and Training Act
 • Apprenticeship and Training Program Overview
 • Child Labor Law
 • Equal Pay Law
 • Industrial Homework Law
 • Medical Fee Act
 • Minimum Wage Act
 • Wage Payment and Collection Law
 • Personnel File Inspection Act
 • **Prevailing Wage Act**
 • Seasonal Farm Labor Law
 • One Call Law (UALPA) and Recording Form

4. Select Online Prevailing Wage Application & Rate Search

Prevailing Wage - Windows Internet Explorer
 http://www.portal.state.pa.us/portal/server.pt?open=51402630=553943mode=2
 File Edit View Favorites Tools Help
 Share Browser WebEx
 Prevailing Wage
 pennsylvania
 DEPARTMENT OF LABOR & INDUSTRY
 STATE AGENCIES ONLINE SERVICES
 pennsylvania PA
 L&I Home
 Safety and Labor-Management Relations
 Industrial Board
 Labor Law Compliance
Prevailing Wage
 Forms
 Quick Links
 Child Labor Law
 Minimum Wage Law
 Safety and Labor-Management Relations > Labor Law Compliance
Prevailing Wage Project
 → [Online Prevailing Wage Application & Rate Search](#)
 Current Labor and Industry Department List
 The Department of Labor and Industry, through the Bureau of Labor Law Compliance, determines prevailing wage rates for the construction industry and enforces the rates and classifications under heavy highway and building construction projects of \$25,000 or more when public funds are involved.
 The Department also determines the prevailing minimum wage rates and employee benefits for specific localities and classifications. The Prevailing Wage Regulations allow the Secretary of Labor and Industry to consider collective bargaining agreements and other types of data for purposes of determining the wage rates.
 Prevailing Wage Act Regulations for Pennsylvania Prevailing Wage Act 19-C1
 (Act of 1961, P.L. 007, No. 447)

5. Select Prevailing Wage Rates Determination Request Form

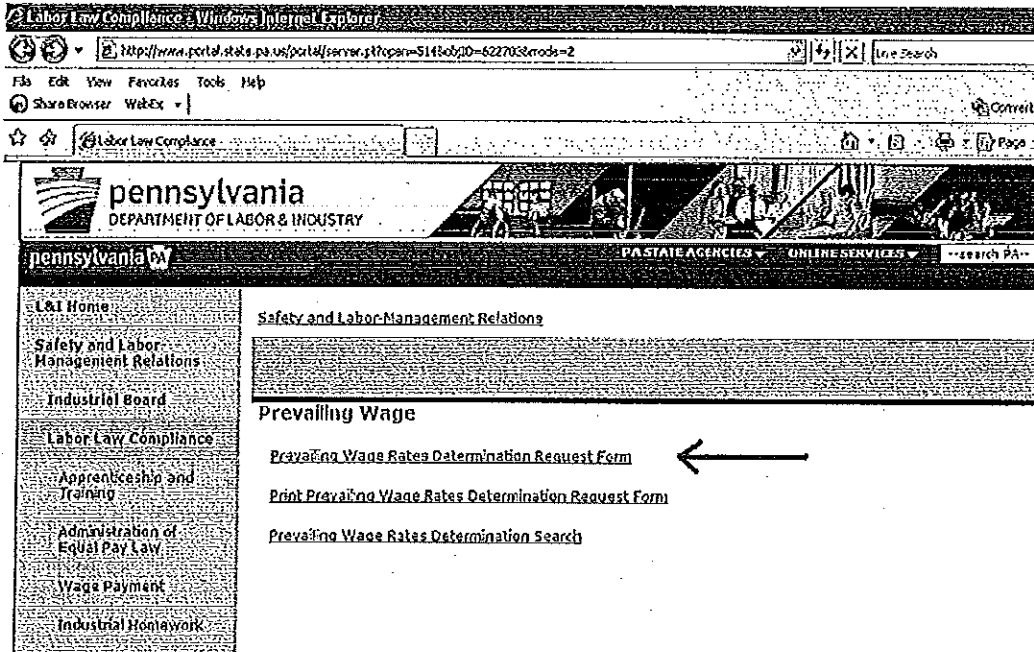

6. The form below will be pulled up. Follow directions to complete and submit.

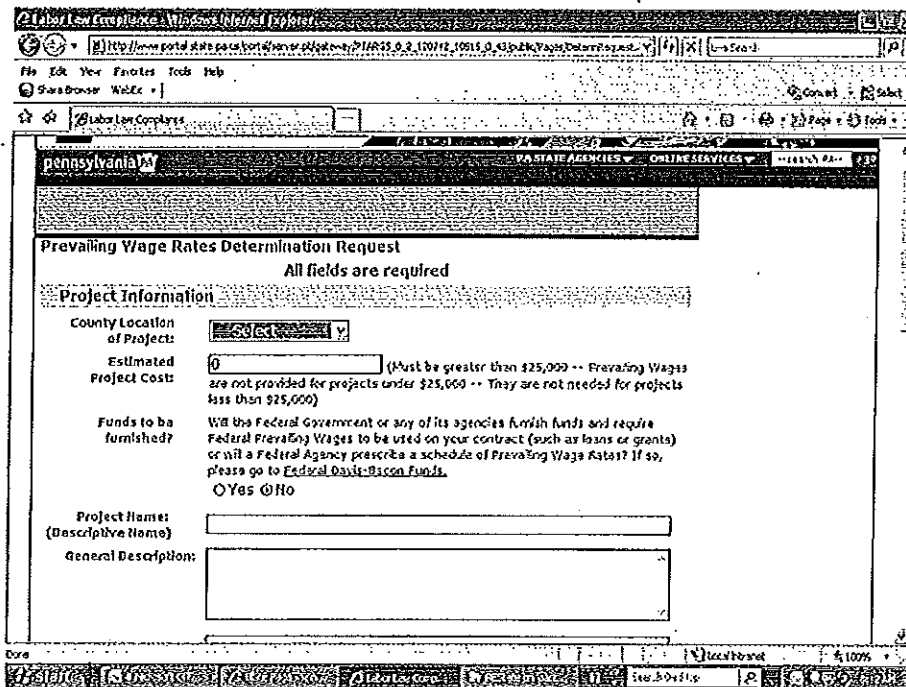

APPENDIX C

COMMONWEALTH OF PENNSYLVANIA

BUILDING SPECIFICATIONS

(Attachment C of New Lease)

PENNSYLVANIA STATE POLICE

Pennsylvania State Police
General Specifications
and
Space Design Criteria

For the

YORK STATION



DATE: 01/5/2015

SECTION A - GENERAL

- 1 - Introduction
- 2 - Location
- 3 - Intent
- 4 - Professional Services
- 5 - Site Adaptation
- 6 - Construction Costs
- 7 - Permits
- 8 - Alterations / Upgrades
- 9 - Access
- 10 - Functional Adjacencies

SECTION B - BUILDING REQUIREMENTS

- 1 - Office Space & Relationships
- 2 - Support Spaces
- 3 - Parking
- 4 - Restrooms
- 5 - Emergency Services
- 6 - Locking System

SECTION C - MATERIALS AND ARCHITECTURAL DETAILS

- 1 - Office Facilities
- 2 - General Construction Specifications
- 3 - Finishes and Miscellaneous Materials

SECTION D - STORAGE FACILITIES

- 1 - Supply Storage
- 2 - Equipment Closet Storage
- 3 - Evidence Storage
- 4 - Janitorial Closet
- 5 - Exterior Storage Shed
- 6 - Radar Kit Storage
- 7 - High Density File Storage

SECTION E - SPECIAL FACILITIES

- 1 - Locker Rooms
- 2 - Restraint Devices
- 3 - Processing Room
- 4 - Restroom near Processing Room
- 5 - Sally Port
- 6 - Polygraph Room
- 7 - Forensic Services Unit

SECTION F - VEHICLE & SITE REQUIREMENTS

- 1 - Parking
- 2 - Impounded Vehicles
- 3 - Parking Space Requirements
- 4 - Exterior Light Poles
- 5 - Signage

SECTION G - DESIGN REQUIREMENTS

- 1 - Design Requirements
- 2 - Codes and Standards
- 3 - Space Planning / Interior Design Services
- 4 - Structural Design
- 5 - Accessibility Requirements

SECTION H - FIRE ALARM, SECURITY

- 1 - Fire Protection
- 2 - Security Monitoring
- 3 - Building Barrier System

SECTION J - ELECTRICAL SYSTEM CRITERIA AND COMPONENTS

- 1 - Electrical Power Distribution
- 2 - Lighting
- 3 - Telecommunications
- 4 - Enterprise Network Data Cabling & Electrical Requirements

SECTION K - MECHANICAL SYSTEM CRITERIA

- 1 - HVAC
 - 1.1 - Temperatures
 - 1.2 - Humidity
 - 1.3 - Ventilation
 - 1.4 - Filtration
 - 1.5 - Pressure Differentials
 - 1.6 - HVAC Controls
- 2 - Plumbing / Utilities
- 3 - Elevators

SECTION L - FINISHED GRADING SEEDING

- 1 - Finished Grading & Seeding
- 2 - Finished Grading & Seeding
- 3 - Landscaping

SECTION M - MISCELLANEOUS CONSIDERATIONS

SECTION N - QUANTITY SUMMARY

SECTION A - GENERAL

1 - INTRODUCTION

The data compiled herein is designed to assist persons interested in offering for lease, facilities (new construction or existing structures) for use as a Pennsylvania State Police Station. This specification is not intended to restrict design, detail or ingenuity of the proposal.

The standards set forth reflect the experience of State Police Officials in this field and have been chosen to provide adequate accommodations.

The Pennsylvania State Police reserve the right to accept or reject any deviation from the specification if in their judgment the variation will / will not compromise the functional intent of the specifications. **All changes to the forgoing specifications and attached related drawings must obtain the approval of the Director, Facility Management Division, Pennsylvania State Police.**

2 - LOCATION

The purpose of this program is to establish the personnel, space and building performance requirements for the Pennsylvania State Police to be located near YORK, Pennsylvania.

This material is based on a review and analysis of existing facilities, an evaluation of the functions and organizational relationships, and the objectives and requirements for the Department's programs in the Law Enforcement area.

3 - INTENT

It is the intent of the following standards to describe the total scope of the project. This description is not intended as a substitute for a complete design / construction document or to eliminate the developer or contractor's need for independent analysis of conditions or requirements. The Commonwealth specifically disclaims any unverified accuracy of this data.

LESSOR and LESSEE agree that specification changes necessary to effectively utilize a specific facility may be made, provided that the LESSOR and the LESSEE agree any such substitution, changes must be made in writing.

4 - PROFESSIONAL SERVICES

The selected LESSOR / DEVELOPER must have a Registered Architect prepare a complete set of drawings and documents for approval by the Department of Labor and Industry. The drawings contained in this proposal **shall only be used as a guide for space utilization and must not be used as a final set of construction drawings.** Prior to construction a complete set of drawings must be submitted to State Police, Facility Management Division, 1800 Elmerton Ave, Harrisburg, PA. 17110. It is intended that the LESSOR/ DEVELOPER will provide a completed structure with fully - developed interior fittings and features. At the completion of the project the LESSOR shall provide the Lessee with a complete AS-BUILT set of drawings in Auto CAD version 2006 or newer release on a CD or 3 1/2" disk and hard (paper) copy, drawn to a minimum 1/8" = 1'-0" scale with-in four (4) months of lease acceptance.

5 - SITE ADAPTATION

The adaptation of these requirements and specifications to a particular design and site or to a current structure is an architectural / engineering design issue which must be resolved at LESSOR's expense as part of the proposal.

The site should have good natural drainage and preferably have an elevation above the surrounding topography. The site should be large enough so that the building may have sufficient room around it to allow smooth traffic patterns and room for future expansion. It is estimated that this facility will require a minimum of 4.5 acres clear of obstructions and wetlands.

Accessibility to roads, where patrols will operate, and availability to the public, influence the location of State Police Stations. Generally, main highways are favored for actual locations, although a reasonable distance off such roads is permissible if a sign can be erected on the main road at the nearest point to the site. Stations near limited access highways should be located close to intersections to permit easy access to the station from both directions.

Adjoining buildings and immediate neighborhoods must be acceptable. The proximity of taverns, racetracks, junkyards and the like may be a major deterrent factor in the acceptability of a site. The Pennsylvania State Police will not consider use as a police station; proposals that offer shared space of any kind within the same building even though physical barriers may separate the spaces.

LESSOR is responsible for all costs related to changes that maybe required by the municipality, as a result of complaints from neighbors. (Example; exterior lighting complaints from neighbors)

6 - CONSTRUCTION COSTS

The Project must be assumed to include all labor, material and equipment. Labor, material and equipment not specifically shown or described but properly inferable from the documents as necessary for the finished project shall be performed and supplied by the LESSOR in accordance with the best recognized standards of the trade.

7 - PERMITS

LESSOR shall be responsible for obtaining all permits and approvals of any kind necessary for the proper and lawful execution of the work. This shall be done at the LESSOR'S own expense. Any alterations that a municipality or a government entity requires to be changed will be at the sole expense of the LESSOR.

8 - ALTERATIONS / UPGRADES

During the lease term, the Commonwealth must be offered the option to upgrade existing space from lower to higher use, or to make additional alterations and renovations to the facility. This offer must apply during the initial term of the lease, the option periods or subsequently negotiated extensions. It is understood that reimbursement will be made to the LESSOR by lease amendment as noted in the terms and conditions.

9 - ACCESS

The Commonwealth requires 7 - day a week, 24 - hour access and use of the premises and lease amenities as necessary.

The facility shall have two separate roads accessing the property. One shall be used for entrance and one for exit.

10 - FUNCTIONAL ADJACENCIES

The proposed facility must normally contain floor space contiguously located in a single structure.

SECTION B - BUILDING REQUIREMENTS

1 - OFFICE SPACE & RELATIONSHIPS

This information shall be used in the layout for the facility, proposed or renovated. Various law enforcement functions require proper grouping to permit the station to operate in an efficient manner. These offices shall be grouped by function in the following: Communications, Crime, Patrol, Specialty Areas, Locker Rooms, Lavatories, Storage, Utilities and Miscellaneous areas. The accompanying generic floor plan depicts these relationships.

2 - SUPPORT SPACES

Mechanical equipment spaces, LESSOR's general storage, hallways shared with other tenants, elevators, stairways or fire towers, utility spaces and other service areas shall complete the building scheme but shall not be included as leased space for purposes of calculating square foot area leased.

3 - PARKING

Persons with disability (ies), visitor, executive, and staff parking, as well as an area for State vehicles must be included along with landscaping and other site amenities. The parking for visitors must be separated from the employee and state vehicle parking.

4 - RESTROOMS

Restrooms shall be provided within the leased space and sized in accordance with the Restroom Fixture Schedule within. The toilet fixture schedule specified below shall be calculated with an approximate percentage breakdown of men and women for each floor occupied by the agency, for each sex.

FIXTURE PER FLOOR		
Number of Men* / Women	Water Closets	Lavatories
1 - 15	3	1
16 - 35	4	2
36 - 55	5	3
56 - 60	6	3
61 - 80	6	4
81 - 90	7	4
91 - 110	8	5
111 - 125	9	6
126 - 150	10	**
Over 150	***	

* In Men's facilities, urinals may be substituted for one - third of the water closet specified.

** Add one lavatory for each 40 additional employees over 125.

*** Add one water closet for each 40 additional employees over 150.

5 - EMERGENCY SERVICES

Emergency services for elevators, plumbing, heating, ventilation and air conditioning, electrical systems, security systems and building structures are to be provided on a four (4) hour call at request of LESSEE. Names of appropriate contracted personnel and optional personnel for these services are to be provided to LESSEE by LESSOR prior to occupancy and are to be kept current during the term of this lease.

6 - LOCKING SYSTEM

The Commonwealth may request and receive a new locking system and / or associated hardware after a break - in or a series of thefts or other similar, unusual occurrences.

SECTION C - MATERIALS AND ARCHITECTURAL DETAILS

1 - OFFICE FACILITIES

The generic floor plan is attached to show the relationship of various functions with-in the proposed facility. The generic floor plan includes a **Room Finish Schedule** that includes the room designations, room finishes and the proposed square footage for each area.

State Police Stations are classified as either a small, medium, larger or extra large station. This facility is designated as an EXTRA LARGE station. Various requirements change based upon this size designation and are noted in other portions of the specifications.

2 - GENERAL CONSTRUCTIONS SPECIFICATIONS

2.1 GENERAL:

Construction material easily and economically obtained at the building site should be given first choice when available without sacrifice to quality. The material and finishes listed are recommended for their economy, their low maintenance requirement and their pleasing appearance. In general the construction of the project facility shall be asbestos free. Materials or components used containing asbestos must be identified by product, material, and manufacturer and percent of asbestos contained by component.

2.2 FLOORS:

- 2.2.1 All footers shall be of plain cement concrete, and shall be pre - engineered for reinforcement. Concrete mix shall be minimum 1:3:5 ratio.
- 2.2.2 Foundation wall shall be constructed of concrete masonry units (blocks) with horizontal joint reinforcement every other course or poured reinforced plain cement concrete.
- 2.2.3 The main floor shall be slab on grade construction, min. 4" thick over a min. 6" stone base complete with vapor barrier and perimeter insulation. In buildings that have a second floor it shall be constructed as an engineered reinforced concrete structure capable of supporting a 100 pound per square foot live load. Insulation between floors shall be an R - value of 22 (min.)
- 2.2.4 Install unglazed Porcelain Tile (18" or 12" square) including a porcelain tile cove base. Rooms designated to be Rubber flooring as defined in the flooring Section (3.2), shall have a 4" rubber cove base. Rubber cove base will need installed in all other areas not identified above. Refer to the finished room schedule found in the proposed construction drawings for the floor finishes by room / area. The flooring material must be placed upon a finished surface that meets all the requirements of the flooring manufacturer. The entire application must be warranted from defects. Following the installation of the furniture and employee relocation a final touch up of the floors will be required to be provided by the Lessor. **VCT is not an acceptable flooring material.**
- 2.2.5 Evidence Room, Evidence Receiving Area and Bulk Evidence shall have two (2) coats of Epoxy with anti-skid surface. The LESSOR shall install rubber flooring on the wooden surface used to complete the installation of the high density movable shelving.
- 2.2.6 The Lessor shall provide and maintain chair mattes at all work areas (desks) to protect the flooring.

2.3 WALLS:

Consideration shall be given to several factors in determining the proper wall construction and finishes, which are:

- Durability (effect of heavy wear)
- Minimum Maintenance
- Sound Absorption
- Initial Cost
- Ease of Cleaning
- Effect of Water
- Fire Resistance

2.3.1 EXTERIOR WALLS:

2.3.1.1 The exterior of the building will be faced with a brick veneer or split face block of the LESSOR's choice.

2.3.1.2 The exterior of the building will be constructed of: 4" brick veneer or split face block, 2"x 6" wood or metal stud framing, 16" o.c., 5-1/2" high density fiberglass insulation, 1" polyurethane board except corners where 1/2" oriented strand board and 1/2" polyurethane board shall be used. (minimum R-22 insulation value)

2.3.1.3 In a multi-story facility the distance from finished floor to finished floor shall be approx. 12'. In a single story facility the distance between the finished floor and the bottom of the roof trusses shall be 10' constructed with (10) foot studding, approximately two (2) feet is required between the suspended ceiling and the bottom of the roof trusses. Allowing space for HVAC equipment and cable management.

2.3.2 INTERIOR WALLS:

2.3.2.1 Many interior walls other than masonry walls shall be framed using 2" x 4" wood or metal framing members, 16" OC. Several areas require framed walls to be 6" thick, including walls with plumbing fixtures, the wall in the Communications Room for EMDF & CMDF panels and the Phone/Server Room. (Also refer to the generic floor plan)

2.3.2.2 The wall separating the Lobby and Public Restroom from the remainder of the secure portion of the station shall be constructed of 8" solid concrete masonry units faced with split face block or brick veneer, extending to the roof. The brick or split face block shall face the Lobby side. The Public Restroom may have a studded wall at plumbing fixtures for plumbing runs adjacent to the block wall in place of the brick. The wall between the Lobby and the Communications Room shall have a writing counter and documents pass space, with bullet resistant glazing between the two rooms. (Refer to detail plan sheet)

- 2.3.2.3 The following rooms shall be constructed to have a finished wall surface of Fiberglass Reinforced Panels (FRP), example; Kemply with Surfseal finish mounted on 5/8" thick plywood. The rooms include the, Processing Room, Restroom near the Processing Room, Public Restroom, Men's Restroom, Women's Restroom, the lower portion of the Fitness Room walls. The Patrol Office and Crime Office will have restraining benches next to the walls that will need to be protected, install the Fiberglass Reinforced Panel material behind the restraint bench and walls adjacent to the security benches, floor to ceiling extending at least four (4) feet beyond the security benches. The Kemply with Surfseal material is manufactured by Kemlite Company, Joliet Ill. Phone 1-800-435-0080 or equal product. Masonry walls that are beside or behind the restraint benches require an epoxy finish and do not require FRP.
- 2.3.2.4 Walls of the Evidence Room, and Evidence Receiving Area shall be **8" solid masonry units** with an epoxy finish. Walls shall be extended above the ceiling line to the underside of the roof deck or the floor deck above to prevent intrusion.
- 2.3.2.5 All other non masonry walls shall be gypsum wallboard and finished with a two (2) coat epoxy application in areas noted on the Room Finish Schedule of the generic floor plan. Reapplication of epoxy to cover the marked or scuffed areas must be performed every 5 years. During the lease the LESSOR will be responsible for all costs to have furniture moved and protected where repainting is performed.
- 2.3.2.6 All interior walls shall be cavity filled with insulation as a barrier against sound transmission. Six (6) inch thick stud walls require additional insulation to reduce sound transmissions example; server room, polygraph rooms.
- 2.3.2.7 Chair rails shall be installed in all offices and areas where desks and chairs are planned including General Offices, Patrol and Crime Unit Offices, Kitchen, & Lobby.
- 2.3.2.8 Site screens and toilet compartments shall be as manufactured as described in Section 3.4.
- 2.3.2.9 Closets in individual offices shall be equipped with one (1) shelf, one (1) clothing rod and shall be lockable. (Note: Equipment Closet or Weapons Closet and Janitorial Closet are listed in Section D)
- 2.3.2.10 The walls of the Communications Room including the masonry walls shall have a sound system acoustical wall covering (Vertex) as manufactured by WSI (Wall Solutions, Inc.) Hazleton, Pa 18201 (1-800-523-6671 or equal product, or an anti-static carpet.)
- 2.3.2.11 The Corridors need to be constructed of concrete masonry walls at least 6" thick with an epoxy finish. The opposite side of the block wall in the office space or areas shall also have an epoxy finish. The Storage Room may be masonry or framed as required by code. The transition where masonry and drywall construction meet must have a clean appearance using an acceptable method used in construction. example; J-bead or trim.
- 2.3.2.12 The Sallyport must be constructed of masonry walls finished with epoxy, The space must meet all applicable codes pertaining to vehicle storage within this portion of the building.

2.3.2.13 The Phone / Server Room must have 3/4" Grade "A" plywood walls for mounting phone and radio equipment. The walls of this room are to be painted black. The mechanical room may require a portion of the walls to be 3/4" Grade "A" plywood. (Exact location of phone equipment to be determined at the Pre-Construction meeting)

2.3.2.14 Install corner guards on walls where potential damage will occur.

2.3.2.15 The Equipment Closet walls shall be constructed of 6" solid masonry block with epoxy finish. An acceptable alternative is standard framing with drywall that is reinforced with extruded steel mesh panels mounted behind the drywall with security fasteners.

2.3.2.16 The interview room(s) walls require installation of acoustical material to eliminate voice distortion while monitoring and recording interviews conducted in room.

2.4 CEILINGS:

2.4.1 Shall be typically a fire rated suspended acoustical system with 2'-0" x 4'-0" acoustic fissured lay - in panels and shall comply with Section 3.8

2.4.2 Restrooms, Locker Rooms, Storage Rooms, and Closets may have optional 5/8" drywall ceiling and painted. (See ROOM FINISH SCHEDULE)

2.4.3 The space above all ceilings shall receive insulation, an R - value of at least 38. Two (2) layers of type X, GWB shall be installed on the underside of the roof trusses to allow insulation to be place above. An R - value of 22 is required between floors. Facilities along or north of Interstate Route 80 require ceilings to be a 49 R value.

2.4.4 Interview Rooms – Install insulation above the ceiling tile to prevent sound transmission from being over heard in neighboring offices.

2.4.5 Typical finished floor to suspended ceiling height shall be minimum 8'-0", a space of approximately two (2) feet is required between the ceiling to the bottom of the roof trusses, except the Evidence Room, Evidence Receiving Area, Fitness Area, Storage Room and the Sallyport may have higher ceilings.

2.4.6 The Equipment Closet and the Evidence Room ceiling (including Evidence Receiving and closets with in the Evidence Room shall be constructed by one of the following methods.

(a) Attach two (2) layers of 3/8" plywood installed in perpendicular directions, nailed and glued, over the plywood shall be a 5/8" thick layer of dry wall which will receive a painted finish.

(b) Construct a 4" thick (min.) Reinforced concrete ceiling and finished similarly to above method with 5/8"thick drywall and painted.

2.5 WINDOWS AND DOORS:

2.5.1 Windows shall be thermopane, Low E glass windows (keeps heat out in summer and allows heat to pass through in winter). Facilities with a single floor must have windows approximately 4'-0" wide X 2'-0"high. Two story buildings shall have the 4'-0" w x 2'-0" h windows on the first floor, larger windows are permitted on the second floor providing the first floor is fully exposed and the exterior grade remains constant. All window units shall be inoperable.

- 2.5.2 Windows shall be placed / spaced according to design. First floor windows shall be a minimum of 6'-0" from bottom of sill to grade on exterior. If necessary the floor elevation shall be raised above grade to accommodate window elevations. There will be no windows in first floor spaces other than those depicted on the accompanying drawings.
- 2.5.3 Install **vertical blinds** as manufactured by Levelor or United Blind Co., or equal product in all exterior windows.
- 2.5.4 Install in the masonry wall between the Lobby and the Communications Room / Reception Area a bullet resistant window unit, with a writing counter on each side of the window finished with Formica.
- 2.5.4.1 The reception window shall be 6'-0" in length and 3'-8" min. in height with the capability to withstand scattered shots from revolvers or pistol of superlative power such as the .44 magnum developing 1470 feet per second velocity and 1150 foot - lbs. Energy at the muzzle, using a 240 grain lead bullet. Provide and install an SVT transaction window, with BALULN25 Glazing System (Level 3) as manufactured by, (Insulgard Security Products, 1291 Rickett Road, Brighton, MI 48116 (1-800-624-6315) or equal product. The unit described is listed by Underwriters Laboratories Inc. The features of this product include a natural voice transmission system, stainless steel voice rails standard base constructed of layered particle board with plastic laminate covering. The base armored with bullet resistant material matching resistance level of window, pass tray stainless steel with bullet -trap below, resistance levels to match window requirements. The manufacturer of the transaction window unit listed will provide a custom counter as shown on the communications window detail. This feature must be requested when placing the order, information is located on the detail sheet.
- 2.5.4.2 The reception counter height shall comply with ADA guidelines from finished floor to top of counter and be 6'-0" in length and 3'-0" in width including the document pass tray. Sufficient shelving shall be installed under the counter on the Communications Room side of the window. Shelving shall have all exposed edges finished smooth and edges rounded.
- 2.5.5 Exterior doors and Equipment Closet doors for the stations weapons shall be 16Ga. galvanized coated insulated steel doors and frames with painted finishes. The exception shall be the Public entrance door, which shall be a store front type aluminum and glass door with matching frame with anodized finish. Exterior doors shall be 3'-0" or 3'-6" wide refer to the drawing for door sizes. The doors must be in compliance with the Americans with Disabilities Act.(See Section 3.6 for additional information) The doors and hardware receive heavy usage including abuse. All maintenance and repairs are the LESSOR'S responsibility.
- 2.5.5.1 The exterior vestibule door(s) at the employee entrance(s) shall be 1 3/4" thick, An Access Control Product as manufactured by Sargent or equal product. The equipment for each employee entrance shall include a Push Button / Proximity Lock model 10-8278 PKL, 500 user keypad lock that is capable of Proximity card and proximity fob control, including a key override. The device must comply with the American with Disabilities Act, be weather resistant and designated for high frequency use, compatible with panic hardware (Sargent single panic hardware PR 8877 x ETL, finish 32 D. Each unit must include all necessary items to make a complete application that is fully functional prior to occupancy by the Lessee. Items may be purchased from the following supplier A.G. Mauro Company, Harrisburg Pa. 717-938-4671, extension 134.

2.5.4.3 Interior vestibule door(s) shall be equipped with appropriate panic hardware. The exterior door at the employee entrance(s) shall be a solid door, the interior vestibule door may have a narrow side lite of glass.

2.5.6 The Evidence Area shall be equipped with steel doors and frames 1 3/4" doors. All doors and frames to be reinforced for hardware (locks, closures).

CHANGE 10/20/14

The Evidence Room must have a deadbolt lock controlled by a key.

The door from the hall to the Evidence Receiving Area must be able to be secured with a keyed lock.

Evidence Area Door	Locking	Door Closure Required
Hall to Evidence Receiving Area, 16 gauge steel door / frame honey comb core 42" wide	Door must be secured with a keyed lock (rev. 10/20/14)	Yes
Evidence Receiving Area to Main Evidence Area, 14 gauge steel door / frame with solid core or honey comb core 42" wide	Door must be secured with a keyed deadbolt lock (rev. 10/20/14)	Yes
Evidence Room closet, either a 16 gauge steel door / frame, honey comb core or solid core wood door 3'-0" wide	Door must be lockable with a key	No

2.5.7 The security door (no windows in the door) between the Lobby and Corridor shall be a flush 3'-0" wide Bullet Resistant Door and Frame UL Level 3 rating. Supplier id is Security Metal Products Model No. BR1-3. The door shall be 12 gauge steel face sheets with 12 gauge steel frames controlled by an electric strike. The electric strike shall be operable from the interior of the Communications Room / Reception Area at three (3) locations, two at the communications consoles and one at the bullet resistant window. This door requires a closure and panic hardware on the Corridor side of the door. The door shall have aluminum continuous geared hinges fully concealed as manufactured by Architectural Builders Hardware Manufacturing Inc., Itasca IL.

2.5.8 Most interior doors shall be 3'-0" flush, 18 Ga. galvanized coated insulated steel doors in metal frames. Evidence Room doors from the hallway plus an access route from the exterior of the building into the evidence room shall have 42" wide doors. A Corridor door will need installed in the hallway separating the space from the Station function this door shall not be lockable. (see generic plan). Corridor doors must be C label doors or as required by code.(see section 3.5)

2.5.8.1 Interior doors shall have a minimum of 1-1/2 pair of hinges (3 hinges) per door. Exterior doors shall have a continuous hinge.

2.5.8.2 Install surface mounted door closures as manufactured by Sargents, LCN or approved equal on restroom (lavatory) doors, locker room doors, exterior and vestibule doors, door between the lobby and the hallway, and storage room doors. The corridors doors (where required by code) will need closures. Install kick plates on the stop side of doors.

- 2.5.9 Furnish 18" x 18" (minimum), one way mirror per Libby Owens Ford Co., Mirrorpane Product or approved equal product. The mirror / glass shall be installed in areas where observation of detainees will be required. The glass shall be gray and have a 4:1 ratio of reflectance, and be located approximately 36" from finished floor.
- 2.5.10 Doors installed on the Interview Room(s), Processing Room(s), or Observation Room(s) **must not contain locks if these rooms have restraining devices for holding purposes**, as described in State Police Special Order 96-123, paragraph (3).
- 2.5.11 Install a commercial or industrial grade 2" min. insulated overhead garage door providing at least value of R-9. The door must be 10' wide x maximum height permitted installed in the Sally port. The overhead door **shall not** have windows. (See Section E-5 for additional details)
- 2.5.12 The LESSOR is responsible for all cost related to maintaining doors, hardware and locking systems in an operating condition. The LESSOR shall install commercial grade heavy duty closures and over swing spring / chain on the exterior doors to prevent damage during high winds, All costs for repairs / replacement will be at the LESSOR'S expense.
- 2.5.13 Doors from the Mechanical Room providing access into the secure portion of the station must be controlled by a lock. The exterior door to the Mechanical Room must also be able to be locked.

2.6 **HARDWARE:**

All hardware for windows and doors, interior and exterior shall be rustproof and hard wearing. Door hardware shall be in compliance with ADA requirements, and installed as previously specified. All doors interior and exterior will be lockable (with the exception as noted in Section 2.5.10). Floor or wall mounted door stops shall be installed on all doors. All exterior doors must latch and must be able to be locked with a key in case the combination device fails.

The Evidence Room and the Evidence Receiving Room require key operated locking.

The LESSOR is responsible for purchasing, installing and making the combination door locks operational prior to building occupancy. The LESSOR is responsible for all costs relating to support that is needed to make the units operational.

Equipment Closet is required to be **secured with a UL 437 listed keyed lock set.**

2.7 **ROOF:**

- 2.7.1 Roof framing shall typically consist of wood truss, 24" on center with minimum 3/4" CDX plywood roof sheeting, designed to prevent ice damming and to handle excessive snow load based upon the geographic region.
- 2.7.2 Weatherproofing shall be of 15 lb. felt paper, 240 lb. asphalt or fiberglass shingles with a Live load of 45 lbs. per square foot for inclined roofs. Flat roofs shall have a live load of 45 lbs. and be constructed of rubber roofing using a fully adhered system.
- 2.7.3 Soffit and fascia shall be aluminum on the roof overhang. An overhang of 2'-0" is required when inclined roofing is used. The building entrances are required to have a roof extension to cover the door in a fully opened position. (See drawing)
- 2.7.4 Install rainwater gutters and downspouts or rain water conductors to direct water away from the building or into storm sewage system. Provide exterior water proof receptacles and heat strips for down spouts and gutters to prevent ice buildup.

2.8 RENOVATION REQUIREMENTS:
Renovation of existing building must be a reasonable match to the generic floor plan for efficiency and flow.

PSP will only consider renovations to existing structures in which the LESSOR provides equal, adequate, and separate temporary facilities during construction to maintain current station operations during construction.

1. Provide parking for
 - a. Employee
 - b. State vehicle
 - c. Visitors
 - d. Handicap
 - e. Impound

2. Provide restrooms and locker rooms for male and female personal must be equal to current station

Additional requirements

- A. emergence power must be provided/relocated

- B. phone, data, electrical, and radio connections must be provided

- C. Due to this being an additional move the Lessor will be financially responsible for the cost of the move

- D. Provide waste water disposal

- E. Domestic water

- F. Heating, Ventilation and Air Conditioning

EXISTING FACILITIES MUST HAVE ALL NEW FINISHES, FIXTURES AND APPLIANCES INSTALLED DURING A RENOVATION. THIS IS REQUIRED FOR ACCEPTANCE OF A NEW LEASE. Examples include but are not limited to new ceilings, wall finishes, flooring, lighting fixtures, cabinets, doors, trim etc. A renovation must include all items identified in the specifications.

3 - FINISHES and MISCELLANOUS MATERIALS

All building materials, systems, components, products and assembly techniques and methods shall adhere to the Lessee's goal of sustainable design and high performance green architecture. The Lessor and design team shall institute a program of construction waste management and recycling that will minimize construction and furnishings waste material going to landfills. All construction material finishes and accessories shall be environmentally responsible and appropriate for use in spaces that are designed for maximum occupant performance. These items shall emphasize low embodied energy, sustainable production, high post consumer material content, be free of deleterious chemicals and compounds, and shall be manufactured and available locally whenever possible.

3.1 FLOORING:

- 3.2.1 Flooring shall be installed in areas as specified in the **ROOM FINISHED SCHEDULE** found on the generic floor plan.
- 3.2.2 **Unglazed Porcelain Tile** – shall be Commercial Grade, Unglazed Porcelain, 5/16” overall thickness 12” x 12” field tile. The flooring choice as manufactured by American Olean, Conshohocken, PA., Telephone number (610) 825-2310 or equal product of another manufacturer. Color to be determined prior to construction.
- 3.2.3 **Grout Joints** – shall be 3/16”, as manufactured by LATICRETE International, Inc, Bethany CT. Telephone number (203) 393-0010, or equal product of another manufacturer. Flooring shall be installed in a workman like manner in strict accordance with the manufacturer’s approved installation instructions, install reducer strips at exposed areas. The Lessor shall follow the manufacturer’s requirements regarding sealing tile and grout joints. Color to be determined prior to construction.
- 3.2.4 **Rubber Flooring** - Shall be resilient rubber seamless flooring (0.14 inches) overall thickness, approximately 46% rubber content. Norament® 925 grano, Article 1880 flooring shall be the flooring of choice as manufactured by Freudenberg Building Systems, Inc. or equal product of another manufacturer. Flooring shall be installed in a workmanlike manner in strict accordance with manufacturer’s approved installation instructions using the appropriate recommended 100% solvent free adhesive. Rout and heat weld all seams. Install reducer strips at exposed areas. In wash down areas, all seams between sanitary base and flooring shall be cold welded together, in accordance with manufacturer’s recommendations. The LESSOR must perform the final preparation of the floors for use following the flooring manufacturer’s requirements, which may include but are not limited to stripping, neutralizing, rinsing, buffing and mopping. The LESSOR must provide Officer-In-Charge and the contracted janitorial service with the manufacturer’s maintenance requirements. **Vinyl Composition Tile (VCT) is not acceptable.**
- The Lessor must supply descriptive data on any flooring material that is proposed as a substitute for the material specified.**
- 3.2.5 **The Fitness Room** shall have a Rubber Roll Sports floor. Non-laminated polymerically bound recycled rubber mixed with EPDM granules or pigmented SBR rubber. Colored rubber particles are homogeneously mixed throughout entire roll. Minimum of 9mm rubber base, 2 mm urethane finish adhered to sub-floor with manufacturer’s recommended adhesive and covered with four coat polyurethane colored finish system. Installation according to manufacturer’s recommendations. As supplied by Dodge-Regupol, Inc, Lancaster PA. 717-295-3400 or Leisure Fitness, Newark Del. 303-266-0666 or equal product, minimum thickness 1/8”, the color to be determined by the station commander.
- 3.2.6 Install commercial grade carpet tiles in offices designated on the Room Finished Schedule of the generic floor plan. The Lessor will need to keep a supply of carpet tiles for replacement of worn tiles to allow a match.

3.3 INSULATION:

The Lessor shall require that all insulation provided for the construction must contain the minimum percentage of post consumer paper or recovered material as shown below for the applicable product:

MATERIAL TYPE	PERCENTAGE BY WEIGHT
Cellulose Loose-fill and spray on paper	75% postconsumer
Perlite composite board paper	23% postconsumer
Plastic rigid foam, polyisocyanurate/polyurethane	
Rigid Foam	9% postconsumer or recovered material
Foam-in-place	5% postconsumer or recovered material
Glass ridge foam	6% postconsumer or recovered material
Phenolic ridge foam	5% postconsumer or recovered material
Rock Wool	75% postconsumer or recovered material

The Lessor shall require the contractor to provide the Lessor with documentary evidence that insulation provided for the renovations was produced with the required minimum percentage of post consumer paper or recovered material as appropriate.

3.4 RESTROOM PARTITIONS:

Toilet/urinals partitions installed in restrooms shall be manufactured using a minimum of 50% recycled High Density Polyethylene plastic coloring and flame retardant agents that are both recycled and recyclable such Perma-Poly panel boards manufactured by EcoTec Toilet Partitions, a Division of N.E.W. Plastic Corporation, Luxemburg, WI or Lessee approved equal. Hardware and installation shall be in accordance with the manufacturer’s recommendations. Color selection to be approved by Lessee.

3.5 INTERIOR DOORS:

The interior doors shall consist of 36” and several 42” wide metal doors refer to the space utilization plan. They shall be finished using nontoxic, water based urethanes or similar environmentally sensitive products, as required by their functions and location. Doors shall be provided with hardware, conformed to the requirements of the Penna. Department of Labor and Industry and all other applicable codes, stops and master keyed locks as indicated by the Lessee.

3.6 EXTERIOR DOORS:

All exterior doors and frames shall be constructed of steel and foam insulation, the only exception will be the main entrance door which shall be a store front type. All hardware shall conform to the requirements of the Penna. Department of Labor and Industry and all other applicable codes. See Section 2.5 & 2.6 for additional information.

3.7 FIRE EXIT DOORS INTO FIRE TOWERS:

Exit doors into stair wells or fire towers shall be the labeled doors as required by the Penna. Department of Labor and all other applicable codes.

3.8 CEILINGS:

All ceilings designated to be acoustical tile shall be acoustical tile suspended by an intermediate duty suspension grid system. Acoustical tile and grid system for ceilings shall be selected to reduce energy costs and provide sustainable design. Acoustical products shall have a Class-A fire resistance per ASTM E 1264 and a flame spread of 0-25 per ASTM E 84 and must have a minimum of 50% post consumer recycled content. Ceiling tiles shall have an 89% minimum light reflectance with a minimum of 35 in compliance with ASTM E 1414, such as the Ultima Hi-LR series as manufactured by Armstrong World Industries, Inc or Lessee approved equal. Ceilings in the locker rooms or area where showers are located are to be moisture resistant. Ceilings in the telecommunications / data room(s) must be acoustical tile on a suspension grid system.

3.9 PAINTS, STAINS AND VARNISHES:

Portions of the building to receive drywall designated to be painted shall receive finishes prior to occupancy. Walls shall be prepared and painted with semi-gloss latex Polomyx paint in at least a four-color mix or LESSEE approved equal. Paint shall be a solvent-free, water-based, and non VOC emitting paint. Preparation and application shall be completed in accordance with manufacturer's recommendations.

Paint for such items as window frames, steel doors etc., shall have a minimum of two coats of paint unless stipulated otherwise. Paint for general interior and exterior applications shall be a water-based, zero- or low- VOC latex paint and primer. Water-based paints shall not be

formulated with aromatic hydrocarbons, formaldehyde, halogenated solvents, mercury or mercury compounds, or tinted with pigments lead, cadmium, chromium VI, antimony and their oxides.

If solvent-based paints are required for exterior use, the VOC levels shall not exceed 250 grams/liter. Solvent-based paints shall not be formulated with more than 1% aromatic hydrocarbons by weight.

The use of water-based stains and transparent finishes for the use of wood finishes shall be provided with less than 200 grams/liter for stain and 250 gram/liter for transparent finishes.

Immediately after occupancy, Lessor will refinish marred walls during weekends or holidays. If occupancy already occurs, painting must be done on weekends or holidays. Color selection to be approved by the Lessee.

3.10 SEALANTS, ADHESIVES AND COMPOUNDS:

All sealants, adhesives and compounds products used in this product shall be non-toxic, low odor and solvent free and shall be anti-microbial with hazardous vapors and contain no carcinogenic materials.

SECTION D - STORAGE FACILITIES

1 - SUPPLY STORAGE

A central storage room shall be provided consisting of, free standing industrial grade metal shelving, provided by the LESSOR. The room is to be used for the storage of automotive equipment and supplies, office supplies, forms, publication storage, and storage of assorted bulk items, i.e. road flares. Section D-5; Exterior Storage Building will be used to store items that are not affected by temperature and humidity changes such as tires and other equipment. The LESSOR must provide shelving and tire racks as manufactured by Lyon.

2 – EQUIPMENT STORAGE

A lockable storage facility shall be provided near the Patrol Corporal's area as a repository for weapons and ammunition storage. The room shall provide shelving, gun racks and hangers for rifles, shot guns, flare guns, hand guns, as well as compartments for riot shields and miscellaneous equipment. Additional provisions shall be determined by the LESSEE.

A gun cleaning counter area approx. 5' in length is required with in the arms closet.

A commercial grade exhaust fan vented to the exterior of the building controlled by a timer switch inside the arms closet is required.

Install two (2) quad electrical outlets near the riot shield storage area for recharging purposes.

Refer to the wall, door and ceiling sections for room construction.

3 - EVIDENCE ROOM (INCLUDES EVIDENCE RECEIVING AND CLOSETS WITH IN THIS AREA)

The LESSOR shall construct the perimeter of the Evidence Room, Evidence Receiving and Evidence Room Closets of **8" solid masonry walls** (See drawing for details). The exterior walls must have insulation to meet the 22 R Value.

3.1 MAIN EVIDENCE ROOM:

Install 5'-0" min. length counter in the main evidence room at a desktop height. Shelving for manuals must be provided in the area of the counter (location to be determined by Officer in Charge).

Duplex electrical receptacles shall be provided every six (6) feet of wall space except where the high density movable shelving is planned. Provide a 20 c.f. refrigerator / freezer with MANUAL DEFROST, a station designated as **a large or extra large facility requires (2) - 24 c.f. unit(s).**

Shelving is needed near the counter in the evidence room for manuals, exact location to be determined by the station commander. Two (2) dedicated electrical outlets and two (2) data locations are needed for computers and printer(s). Install at least one (1) non-dedicated duplex receptacle in the closet(s).

The LESSOR shall provide mobile storage shelving in the evidence room. The shelving shall be able to store various sized evidence and able to be stacked to the side as well as being moveable. The system shall have support rails either mounted in the concrete floor or on top of the floor. Where the rails are placed on top of the concrete floor a wooden floor must be constructed to create an even surface between the rails the floor will need to be finished with rubber flooring.

A supplier of this equipment is Storage Tek Inc. or equal product of Hummelstown, PA (717-566-7158). The generic plan shows the general location of the mobile shelving with in the evidence room. Calculations of linear feet of shelving needs based upon an existing two (2) feet wide shelf. Refer to the **QUANTITY SUMMARY** in SECTION "N" found at the end of the general building specifications for the amount of linear feet of shelving required for this project.

Mobile shelving widths range from 1'- 0" to 3'-0", the station commander will need contacted to assist with the details of the movable shelving. Additional fixed wooden or industrial grade metal shelving may be required, not included in the Quantity Summary.

The evidence closet that is accessible only from the main evidence room shall be lockable. It will require storage shelving for long and short guns, gun racks, shelving for illicit substances and valuables. Multi-tier storage lockers or security evidence lockers may also be required where present at the current facility to accommodate current and future needs in the secure evidence storage closet. The layout of the closet will be based upon the current method of storage at the station which could be gun racks or space to lay boxes flat in the closet. Refer to the detail sheet that shows storage box sizes for firearm evidence and planned method to store items. The closet will require 1 duplex outlet.

3.2 EVIDENCE RECEIVING AREA:

Counter space at standing height is required in the Evidence Receiving Area approximately five (5) feet in length. Two (2) dedicated electrical outlets and two (2) data connections are needed for computer and printer(s). Several non-dedicated duplex outlets are needed. Provide and install one (1) 20 cu. ft. full size refrigerator / freezer unit with MANUAL DEFROST in the Evidence Receiving Area. A large or extra large station shall receive a 24 cubic foot unit.

Install two (2) standard duplex electrical outlets, one for the refrigerator.

Install steel security evidence lockers in the Evidence Receiving Area. The lockers shall consist of a total of (3) lockers including;

one (1) single tier locker 18" w x 18" d x 72" h,

one (1) double tier locker 12" w x 18" d x 72" h

one (1) triple tier locker 12" w x 18" d x 72" h

Each locker shall be keyed separately, two (2) master keys shall be provided. The lockers are available from the following: Robinson Steel Company (610-279-6600) Penco Products Inc., Greenville N.C. (800-562-1000); Republic Storage, Canton Ohio (800-477-1255); Hadrian Inc. Mentor, Ohio (440-942-9918) or equal product of another manufacturer. (updated 6/2014)

4 - JANITORIAL CLOSET

A Janitorial Closet shall contain a Utility Sink as well as shelving and racks for cleaning equipment to meet the needs of the facility.

5 - EXTERIOR STORAGE SHED

The LESSOR shall provide a non-permanent storage shed, a minimum of 14' wide x 20' long x 8' high. The shed shall be placed on an improved surface example; stone pad or macadam. The macadam must not reduce the total number of parking spaces required. It should not have any windows and must be able to be locked. The exterior finish shall be vinyl siding to eliminate repainting. The base of the storage shed must be constructed of pressure treated lumber.

The storage shed shall have tire racks at least two (2) levels high and shelving to accommodate the stations needs as manufactured by Lyon. Additional tire racks may be required in the main storage room.

6 - RADAR KIT STORAGE

The space utilization plans show an area offset in the hallway near the patrol office for the storage of radar kits. Shelving shall be constructed several levels high to accommodate the various sized radar kits. The tallest kits are 20" high, and the longest kits are 23" long. The shelving shall be covered with a material resistant to gouging or marking. Metal trim strips on the edges shall be provided to preserve a like new appearance.

7- HIGH DENSITY FILE STORAGE

The LESSOR is required to provide and install High Density File Storage at the facilities where the **generic floor plan indicates this type of filing is needed (typically file room and clerk area)**. The amount of high density filing shall accommodate the existing filing needs and future expansion. Where a built up floor is needed surrounding the high density filing it is required to have a finished floor surface to match the remainder of the room. StorageTek or equal product of Hummelstown PA (717-566-7158) is a supplier and may be contacted by the LESSOR.

SECTION E - SPECIAL FACILITIES

1 - LOCKER ROOMS / EMPLOYEE RESTROOMS

The LESSOR shall provide and install lockers with doors the lockers maybe cabinet grade millwork or metal refer to the generic floor plan for the number of lockers in each locker room. The **Quantity Summary** SECTION "N" at the end of the specification lists the total number of lockers required. Each locker shall be 36" wide x 24" deep x 84" high. The lockers shall extend from the floor to ceiling (pressboard or OBS board construction **is not** acceptable). Lockers shall have a base that raises the locker several inches off the floor, to create a kick plate the exterior of the base shall be covered with cove base. (Concrete base is not acceptable). Each locker must have a lower compartment for the storage of a riot gear duffle bag and boots, it must be constructed to support the weight of at least 35 lbs. This compartment must have a separate set of doors that **are not lockable** to allow easy access to this portion of the locker in an emergency. A detail of the locker appears on the detail sheet. A supplier of metal lockers is LYON, the size is 36"w x 86"h approx. x 24"d. A contact number is 330-758-6616.

The remainder of the locker shall be lockable. The Officer-In-Charge shall choose the type of locking mechanism of each locker in the locker rooms.

1. Each locker must provide hardware to permit a combination lock to be used to secure the locker.
2. The locker shall contain a lock, keys shall be provided for the lockers as well as two master keys to open all lockers.

Each locker shall contain a clothing rod that extends the entire width of the locker, for shirts, pants and coats. Lower in the locker below the clothing rod are two shelves that extend approximately 2/3 the width of the locker. The lowest portion of the locker is a compartment for riot gear and boots this portion of the locker must support weight of at least 35 lbs. of equipment. The riot gear section if the locker shall not be lockable.

Locker rooms shall be supplied with benches that are mounted to the floor.

Shower stalls are to be installed as shown on the drawing, one shower per locker room must comply with American with Disabilities Act. Showers shall have controls and shower heads. Shower curtains must be installed at each shower. Moisture resistant drywall is required in the rooms where showers are located. Appropriate ventilation must be provided to remove excessive moisture and humidity. The ventilation system shall be automatically operated by a humidistat with manual override.

The restroom area shall be incorporated in or next to the locker room facilities. A full length mirror shall be provided in each employee restroom / locker room. Mirrors are also required at each restroom sink. Suitable counter area or a metal shelf is needed at each sink. It is acceptable to use a shelf / mirror combination unit at each sink.

Electrical outlets for personal grooming are needed in the vicinity of the mirrors with ground fault protection. Individual lights need placed above each sink in addition to standard ceiling lighting.

The LESSOR must install all soap dispensers, paper towel dispensers and toilet tissue dispensers that will accept the State Police supplied paper goods.

Briefcase Racks - are generally located in or nearby the locker rooms, the briefcase racks/shelving shall be of sufficient size to provide each trooper with space for a briefcase, the total number of briefcases being accommodated shall match the number of lockers per locker room. Allow 16" width x 18" height per briefcase, racks/shelving may permit several briefcases per shelf as opposed to individual cubical. The briefcase racks shall be finished with carpet and metal trim on the edges. The racks / shelving shall be of sufficient strength to support the weight being held. Refer to the generic floor plan for location.

2 - RESTRAINT DEVICES

The LESSOR will be required to mount restraint benches at locations shown on the generic floor plan. The restraint benches will be provided by State Police.

3 - PROCESSING ROOM

The Processing Area requires a sink, counter space, above and below counter cabinets. Provide two (2) 15 AMP dedicated circuits for Live Scan equipment, two (2) dedicated 15 AMP circuits for photo imaging equipment (CPIN), one (1) dedicated 20 AMP circuit for Megan's law computer equipment. A specific equipment layout for this room is shown on the floor plan. Video arraignment equipment may be placed in this room requiring additional electrical outlets. Additional electrical outlets are required for future equipment. Provide at least 8 dedicated electrical outlets in this room.

The room shall be constructed of fiberglass reinforced panels over plywood or kemply with surface seal to prevent the walls from being damaged by an unruly prisoner.

Photo image equipment requires a laminated surface facing the equipment placed upon ¾" grade "A" (4' x 8') finished sheet of plywood to be hung on the wall opposite the camera. The finish shall be a matte finish gray Formica #928-58 "mouse" matte finish or similar, 18% gray background. Provide a finished edge of Formica or banding as supplied by Wirth Baer Supply Company, 900 13th Ave. Bethlehem, PA 18018, Phone (610-694-0311)

Additional outlets are needed for video arraignment computer equipment and the Megan's law computer, scanner, printer. At least eight (8) enterprise data sites are required in this room. (updated 8-15-12)

The equipment in this room produces excessive heat and must be on its own heating and cooling system. Upgrades in equipment during the lease will likely change the HVAC requirements. It is the LESSOR'S responsibility to maintain temperatures as contained in the lease.

A weapons storage box needs provided and mounted in this room. (The location determined by the Officer-in Charge)

4 - RESTROOM NEAR PROCESING

A restroom shall be provided in close proximity to the Processing Room. It shall have a water closet and sink that comply with ADA. A mirror and paper dispensers are also required.

The room shall be constructed of fiberglass reinforced panels over plywood to prevent the walls from being damaged by an unruly prisoner.

5 - SALLY PORT

The Sally port shall have a commercial grade insulated overhead garage door 10'-0" wide (no windows). The area shall be in close proximity to the patrol room for prisoner control in the facility.

The overhead door requires a garage door opener, controlled by a combination device mounted on a pedestal along the driveway leading into the Sally port. The combination device must be protected from inclement weather. The overhead door must also be operable from inside the Sally port by a push button device and from a control switch in the communications room. (locations to be determined by the (Officer-in Charge)

Two (2) floor drains are required in the Sally port one (1) beneath the vehicle to allow snow / ice and water to drain from the vehicle. This drain needs to allow for sediment to be removed, to include a sediment basket and trap. The second drain shall be installed at the emergency shower also in the Sally port.

Two panic alarm activation buttons need to be installed in the Sally port, One needs placed near the driver side door and the other shall be on the opposite side of the car near the rear passenger door. The alarm it will sound an in the Patrol Room, Patrol Cpls. Office, Hallways and the Communications Room. The sound of the alarm shall be different than any other used in the building.

This area shall also be used for occasional vehicle storage and processing.

6 - INTERVIEW ROOM / POLYGRAPH ROOM

Interview Rooms and buildings designated to have a Polygraph Room shall;

1. Have sound proofing which includes preventing sound from being heard over the walls through the ceiling. This room requires framing to the bottom of the ceiling trusses, insulation in all walls and ceiling, insulation in trusses, as well as gasket, interlock, and insulation on the door threshold and frame.
2. Have a panic alarm button provided in the room to activate an audible alarm that will sound in the Crime Unit and in the Communications Room, the sound of the alarm may be the same as identified for the Sally Port.
3. Have an occupied sign and must be installed in accordance with specifications outlined below; The sign must be internally illuminated, be mounted at a 90 degree angle to the wall centered above the top of the door frame. The sign must be activated from within the room.

7 - FORENSIC SERVICES UNIT (Provided only at facilities where shown on the generic floor plan updates for Media Station included 2/6/14)

The Forensic Services Unit shall have laboratory style locking base cabinets, over counter cabinets, a stain resistant epoxy resin counter, with a one piece epoxy resin tub sink catalogue # VF-1003-00 (18"x11"x15") as supplied by VWR International LLC, Telephone # (717) 475-0018. The Lessor shall refer to VRW representative for layout recommendations.

Also required:

A 6' x 2' counter with cabinets for photography equipment

18" x 18" x 6' lockable storage locker as indicated on the plan

A floor drain

A minimum of 2 additional circuits (with GFI protection) at the laboratory counter

5 cubic foot refrigerator below counter with hasp and lock to secure door.

Several walls of the room shall be finished with fiberglass reinforced panel (FRP)

The following items are supplied by VWR International LLC or equal products,
Faucet /Eyewash combo; catalogue # 3880-032
Laboratory grade faucets with hose adapter, catalogue # VFT-034-OV,

A Laboratory grade fume hood Model number 2247300; SKU: VWR # 30152-518 manufactured by Labconco supplied by VWR International LLC, the fume hood shall be installed by the LESSOR, placed on a base cabinet by LESSOR as shown on the generic floor plan. The LESSOR shall provide all connections to the equipment and must install all necessary duct work, motors, circuits etc. as specified by the manufacturer to make the unit operational and exhausted to the roof with sufficient make-up air supply. A duplex receptacle is required on the right side of the fume hood and a light is needed inside the fume hood. The fume hood will need a motor and blower 115 volt 60 Hz. In addition, the LESSOR shall have the supplier test and certify the fume hood to verify the system is operating with in the manufacturer's specifications.

Locations that currently have a forensic evidence drying cabinet as manufactured by Sirchie (supplied by State Police) will be relocated in the Forensic Services area. The LESSOR must provide a cold water supply 1/2" threaded PVC and a fixed drain line for the unit as well as electrical power.

SECTION F - VEHICLE and SITE FACILITIES

1 - PARKING

On - site private parking is required and shall be located adjacent to the facility. Lighting in the parking area shall be dusk to dawn and shall be automatically controlled. All parking areas shall be paved and striped for parking. All parking spaces shall be marked as designated by LESSEE. Parking spaces shall be a minimum 10'-0" wide and 20'-0" long, handicap provisions will apply to spaces so designated. The parking area shall not exceed a slope ratio greater than 1:20 in any direction. Apply painted 4" wide white lines using traffic paint conforming to the Federal Specifications TT-P-115, Class "A". A one (1) coat application will be acceptable if good cover is achieved. All macadam line painting shall be repainted at least every two-(2) years.

Driveways with two-way traffic must be twenty-four (24) feet wide, driveways for one way traffic must be at least fifteen (15) feet wide. The Sally Port entrance requires a driveway access. Driveways and parking areas shall have galvanized metal guide rails (as required by PENN DOT) installed where sudden changes of elevation cause hazardous conditions. Guide railing at the main entrance to the parking area should be 28' between guide rails unless restricted by Penn Dot. The facility shall have two separate roads accessing the property. One shall be used for entrance and one for exit.

A grass area at least 75' in diameter clear of trees and obstructions is required on the site, as well as an area to approach and depart the clear area.

Sidewalks must be provided to **all** building entrances from the macadam parking area, including the mechanical room entrance.

Install a concrete pad for a dumpster adjacent to the driveway.
Perimeter of the parking areas and building require pole mounted lighting further defined in the Security Section H, Item 2.

Existing Construction: requires all damaged existing macadam to be repaired with full depth patching. The entire existing macadam surfaces shall be leveled to provide proper drainage and an overlay applied.

2 - IMPOUNDED VEHICLES

- 2.1 Construct a paved vehicle impound area with two macadam access routes leading to the impound. Refer to the **Quantity Summary**, SECTION "N" at the end of the general specifications and the proposed site plan for additional information.
- 2.2 Construct a chain link fence, surrounding a paved impound area. The fence shall consist of a 9 gauge, 2" woven wire mesh with upper and lower rails to securely fasten the fence fabric or at minimum an upper rail and a lower tension wire. The chain link portion must be 8'-0" high with three (3) strands of barb-wire at the top angled out at 45 degrees from the perpendicular. The bottom of the fence fabric must extend to within a maximum of 2" of the ground. Post spacing shall not exceed 10'-0" O.C., concrete footings and pipe sizes for line, gate and corner posts shall be determined by the manufacturer.
- 2.3 Install two (2) entrance gates each approx. 20' wide to secure each entrance. Install either a single gate that operates parallel to the fence or a double swinging gate at each entrance. The gates must have hardware to provide a point to secure the gates with an industrial grade pad lock (this is not the standard drop post and bracket that keeps the gates from swing out). Hardware should provide a protective hood to prevent the shank of the lock from being cut thus it will eliminate the need to use a chain to secure the gates.
- 2.4 The facility will require a second fenced in area required to surround generator & propane tanks. It may also surround a radio tower if required at the station. For additional information refer to Section J-3 Telecommunications and Pa. State Police Communications Specifications.

3 - PARKING (VARIES BASED UPON FACILITY)

- 3.1 The State Police require Visitor Parking to be separated from employee and state vehicle parking refer to the generic site plan. Visitor parking must be easily accessible to the main entrance.
- 3.2 Vehicle spaces for use by persons with disabilities must be provided including van accessible spaces to accommodate side lift vans. An ADA parking space will be needed near an employee entrance. (The number of spaces for persons with disabilities will vary based on total spaces)
- 3.3 Vehicle impound spaces are included in the total number of parking spaces required for the facility.
- 3.4 Refer to the **QUANTITY SUMMARY**, SECTION "N" at the end of the General Building Specifications for the break down of parking space needs. The municipality may require additional parking spaces.

4 - EXTERIOR LIGHT POLES

- 4.1 The light poles in the parking area or next to the parking lot shall be placed on a concrete base that will extend 36" above the macadam to prevent damage to the lights.
- 4.2 Provide the required foot candle of lighting in the parking area and impound lot as noted in the lighting requirements. Reductions in exterior lighting will only apply where the municipality requires a reduced foot candle value. The LESSOR is responsible to install shields or barriers in the direction of neighboring property owners to prevent complaints of excessive light spilling onto their properties. Costs to make corrections deemed necessary by a municipality will be the LESSOR'S responsibility.

5 - SIGNAGE

The Pennsylvania State Police will provide an identification sign for the specific facility. The LESSOR shall install the sign in front of the building to permit the public to observe the sign. The sign will require supports constructed of either brick, split face block, stone or pressure treated lumber. It will need secured to prevent the sign from movement during high winds. Provide automatic illumination of the sign. (A photo of the sign is provided at the end of the specification the size of the sign is 4'-0" wide by 4'-0" high.)

The LESSOR must provide and install all interior office and area signs, braille must be included on each sign to be ADA compliant.

All Exterior signage relating to Americans with Disabilities (ADA) must be provided by the LESSOR. Parking spaces require a sign placed in front of each space complying with ADA. A van accessible sign must be displayed at the space(s) meeting this requirement. Separate signs at each ADA space shall state "Violators Subject To Fine and Towing. Minimum Fine \$50, Maximum Fine \$200". Building entrances that are accessible must be identified.

Other exterior directional, parking, vehicle identification signs will be provided by the Commonwealth, however the LESSOR will be responsible to provide and install posts and secure the signs on the posts.

Provide and install a mailbox, with address numbering for the station where rural postal delivery is required.

SECTION G - DESIGN REQUIREMENTS

1 - DESIGN REQUIREMENTS

The following general design requirements shall apply to the design of all areas unless specific exception is noted for the item in question in the proposed Facility Plans, or where specifically exempted by prevailing law or superseding regulation. NO GRAND FATHERING OF ANY LAWS, CODES OR STANDARDS WILL BE ALLOWED.

2 - CODES AND STANDARDS

Act No. 166 of the 1988 Pa. Legislature (or later revisions) regarding persons with disability (ies). Applicable sections of the ANSI and ADA, Act 101-336 of 1990 shall supersede the PA Acts when PA Acts are less stringent.

Society for Environmental Graphic Design: "Clarification and Interpretation of the ADA Signage Requirements."

BOCA National Code /Series - Latest Edition, including Basic Building Code; Fire Prevention Code; Mechanical Code; and relevant codes and standards referenced therein.

Fire and Panic Code - Pennsylvania Department Of Labor and Industry.

Pennsylvania Act 222 - Building Energy Conservation Law. Energy Policy Act of 1992 (P.L. 102-486)
Local Zoning Ordinances - latest edition with all amendments.
Latest Edition of the International Building Code.

The latest revision of ASHRAE/IES Standards 90.1 "Energy Efficient Design of New Buildings Except Low - Rise Residential Buildings."

OSHA - Latest edition (July 1, 1982. Plus subsequent revisions to date).

NFPA 101 - Life Safety Code, latest edition.

Hazardous Material - No asbestos insulation or asbestos-based materials may be used in construction or remain on the site. Hazardous materials notification, as required by law, shall be provided to LESSEE who will notify affected employees.

Radon Gas Exposure - The site shall be evaluated prior to occupancy for radiation level and Radon / Radon Progeny concentration. If Radon / Radon Progeny levels are above EPA Recommended Standards as existing at the time of occupancy of the premise by LESSEE, plans for corrective action in the HVAC specifications will be required. If at any time during occupancy the Radon / Radon Progeny levels exceed the EPA recommendations at that time, the LESSOR shall take necessary corrective action upon notification in writing by the LESSEE. Such action must be taken within two months of the notification. **Radon testing results must be submitted to Penna. State Police, Facility Management Division, 1800 Elmerton Avenue, Harrisburg, Pa. 17110 at the time of lease acceptance.**

Zoning - The facility must be located in an appropriately zoned site and must allow operation which would include the occasional handling of small samples of hazardous and potentially toxic substances, as well as permitting radiological equipment on-site.

Flood Plain - Both site and access must be outside the 100 - year flood zone as defined by the Federal Emergency Management Agency, United States Army Corps of Engineers and the Pennsylvania Department of Community Affairs.

Wastewater - Any proposed facility may be connected to either public or private sewer and water systems. These systems must have legal and adequate treatment systems and capabilities for the proposed use. The resulting connections and/or utilization of either public or private systems must be in compliance with local, state or federal laws, rules and regulations. It will be the responsibility of the LESSOR to provide the operation and maintenance of the system or systems and cost thereof.

Drinking Water - LESSOR shall provide and maintain hot and cold bottled drinking water in locations designated by LESSEE if testing and treatment of on-site water does not meet drinking water standards. The LESSOR is responsible to provide potable drinking water for the facility. Potable water shall be defined as water that satisfies the Department of Environmental Protection, Bureau of Water Supply and Public Health Standards. Additionally, the water must be free of contaminants, odors, impurities and discoloration of any kind. The LESSOR will be responsible to provide purification, filtration or any other means necessary to achieve water that is acceptable to the State Police. Facilities required to be connected to a public water system, as well as all costs related to water usage and maintenance thereof shall be the LESSOR'S responsibility.

Sound and Noise Control - The LESSOR shall maintain construction practices and materials to conform with STC ratings in accordance with ASTM E-90-83, and the requirement to the specification and drawings.

3 - SPACE PLANNING / INTERIOR DESIGN SERVICES

The services are to insure that the final character and configuration of the new space, furnishings, and equipment fully satisfy the functional and aesthetic requirements of the LESSEE while meeting all applicable codes and regulations. If there is a conflict between the drawings and the specifications, the specifications shall prevail. These services shall include but are not necessarily limited to the following;

- Development of work schedule to meet project deadlines.
- Verification of the various project requirements, personnel counts, and space allocations contained elsewhere in this document.
- Establishment of adjacency requirements.

- Verification of vacant and projected positions.
- Identification of furnishings and equipment being supplied by the Commonwealth and accommodating the new facility.
- Development of typical work station based on Pennsylvania State Police requirements.
- Documentation of power and signal requirements for each workstation, office, or special area and preparation of all related drawings.
- Recommendation of interior finishes, colors and materials, the preparation of illustration or color boards based on proposed finish schedule.
- Physical verification of all interior building dimensions and conditions.
- Preparation of construction drawings based on the Commonwealth proposed drawings as advertised.
- Review and revise construction drawing as required to gain final LESSEE approval.
- Schedule and coordinate the delivery and installation of all interior items including the refurbishment of previously owned items.
- Visit the job site as required during the course of the project to resolve any problems that may arise and monitor the quality and progress of installation of all interior items.
- Participate in the final inspection and preparation of the punch list for all interior items.

4 - STRUCTURAL DESIGN

The LESSOR shall design the required space such that the following minimum live loads are permissible in all areas of the structure:

Office Floors - 100 PSF
File / Storage Floors - 200 PSF

5 - ACCESSIBILITY REQUIREMENTS

The facility must maintain barrier - free accessibility in the following areas or as required by law or code:

Entrances and exit ways and hallways
Access to each floor of the structure
Toilet rooms and lavatories
Designated parking areas

The construction of the facility shall meet the latest standards of the Americans With Disabilities Act (ADA). Items contained on the drawings that do not comply with the requirements shall be the LESSOR's responsibility to construct properly. The LESSOR may obtain a copy of the ADA Guidelines the internet at www.access-board.gov/bfdg/adaag/html/adaag/htm#4.3.11

SECTION H - FIRE ALARM, SECURITY

1 - FIRE PROTECTION

The LESSOR shall provide hand-held ABC substitute fire extinguishers in areas of concentrated electrical / electronic equipment as designated by the LESSEE. The fire extinguishers need to be at least 5 lbs. in size, placed near all exits, Telephone/ Server Room, Communications Room, Storage Room, and Kitchen. Install at least six (6) fire extinguishers or additional as required by code.

Hand-held ABC extinguishers shall be provided and serviced annually by the LESSOR as required by code.

Fire extinguisher cabinets shall be the Vista Series as manufactured by Larsen's Manufacturing Company or equal products of another manufacturer.

Provide and install smoke detectors that are UL and FM approved. Smoke detectors shall be placed in Corridors, Evidence Rooms and Storage Room. Smoke detectors shall provide audible and visual warning to comply with ADA, and must be tested annually.

Municipal codes may require a fire alarm system to be installed in the facility. Where this is required the LESSOR shall be responsible to provide and maintain the system.

2 - SECURITY MONITORING SYSTEM

The LESSOR shall provide and maintain a fully operational security monitoring system with cameras, cabling, power etc. to observe and record activity at all of the building entrances, the parking lots, vehicle impound area, the perimeter of the facility, the sally port and the entire lobby. The Communications Room is the designated area to observe the security equipment which includes a minimum 32" monitor, multiplexer and digital recorder. The interview room must have a camera provided and installed to allow recording of interviews and shall be observed and recorded within the Crime Supervisor area and should not be part of the exterior building monitoring observed in the communications room. The LESSOR will be required to maintain the system as well as all costs involved. Observation of neighboring property is prohibited.

The cameras will need mounted on the building placed to observe the areas identified above. Site conditions may require the security camera for the impound lot to be mounted on a pole at an elevation that will view the impound lot. The security monitoring system selected must meet the approval of the Station Commander. Prior to installing a system the LESSOR must arrange for the Station Commander to visit a facility that has a similar security monitoring system that is operational to determine that it meets the needs for the station.

Monitoring cameras previously placed on light poles have been discontinued because conduits from the building to the poles become damaged and are not able to be used. Thus the cameras need mounted on the buildings. Contractors that have provided systems for the State Police at other facilities include: Berkshire Systems Group, Inc (1220 Center Avenue, Reading, PA. (610-374-5593), Wacor Electronics, East Petersburg, PA. (717-581-1008) or equal

Two panic alarm activation buttons need to be installed in the Sally port, One needs placed near the driver side door and the other shall be on the opposite side of the car near the rear passenger door. The alarm must be a specific tone that sounds in the Patrol Room, Patrol Corporal's Office, hallways and the Communications Room. Buildings designated to have a Polygraph Room shall also have a panic alarm that will sound in the Crime office and Communications. The same tone maybe used for both panic locations.

3 - BUILDING BARRIER SYSTEM

The LESSOR shall install metal or concrete bollards approx. 8" in diameter. The finish of the bollards shall be a material that does not require repainting (example; plastic sleeves). Bollards need installed to protect the following items:

- a. The front of the building closest to the highway and the sides of the building. The placement shall prevent a vehicle from passing between the bollards.
- b. Both sides of the overhead door to protect the exterior walls.
- c. On both sides of the exterior overhead door control device.
- d. Any building system equipment located with-in five feet of a driveway.
- e. Between the driveway / parking areas and propane tanks where used for the emergency generator

SECTION J - ELECTRICAL SYSTEM CRITERIA AND COMPONENTS

1 - ELECTRICAL POWER DISTRIBUTION

Characteristics to be provided to the LESSEE include:

115 volt, 60Hz, with common ground and surge protection
208/230 VAC, 60Hz, 3 Ph.

The LESSOR must provide all electrical needs to provide electrical power throughout the term of the lease.

115 volt, 60Hz with Isolated Ground and Surge Protection

The LESSOR must provide electrical power to all work stations; this includes all connections required by a furniture vendor to make the work station units operational. **At each proposed work station a minimum of four (4) outlets are needed (a quad outlet or 2 duplex outlets). The outlet designated for the computer is in addition to the (4) general outlets.**

The Lessor shall supply 115V, 20A, 60Hz, identified isolated ground circuits to work stations in the following circuit configuration:

- (a) No more than FOUR (4) personal computers per 20 amp circuit.
- (b) No more than TWO (2) laser printers per 20 amp circuit. Printers will not be located at each computer, several work station computers will be connected to a printer. A guide to use would be a printer for every 8 computers, the locations of printers will be determined.
- (c) No more than ONE (1) multi-function copier, scanner fax unit per 20 amp circuit
- (d) No more than FOUR (4) utility receptacles per 20 amp circuit.

Duplex wall outlets must be provided in all rooms in addition to the dedicated outlets that are identified the distance between wall outlets shall not exceed six (6) feet. The only exception to this is the Evidence Room that is addressed in Section D, item 3.

Transient voltage surge suppression must be on all electrical panels servicing isolated circuits and normally grounded circuits.

Exterior outlets – install a total of four (4) exterior outlets; one (1) near the storage room entrance; one (1) near the main entrance. The other two (2) shall be accessible to the parking lot at a level area for speedometer testing for MCSAP. Install additional exterior water proof receptacles and heat strips for down spouts & gutters to prevent ice build-up.

The Equipment Closet requires two (2), quad outlets to be installed near the riot shield storage for recharging purposes.

Charging Areas - Provided a group of duplex and quad electrical outlets at an area(s) designated for various types of chargers (examples; flashlights, portable radios, etc.) location(s) to be determined by the Officer-In-Charge.

The Processing Room – Install at least 8 dedicated electrical outlets in this room. Photo imaging equipment (CPIN) and printer require two-(2) dedicated 15 amp electrical circuits. The Live Scan system requires two (2) dedicated 15 amp electrical circuits for computer and printer. Megan's Law computer requires one (1) dedicated 20 amp circuit. Video arraignment computer equipment needs one (1) electrical outlet. Install a minimum of four (4) additional duplex outlets for future equipment. Avoid installing electrical outlets at the retraining bench.

The Telephone / Server Room requires general use electrical outlets in addition to those identified in the attached Pa. State Police Communications Specifications.

Conference Room – Provide and install electrical outlets and data connections in the floor beneath the conference room table. The devices used must be protected from water used when cleaning the floor.

The Lessor must provide for at least 25% future electrical distribution panel circuit breaker space at the time the lease begins. In case State Police do not have funding for new furniture at the time of occupancy base the electrical needs upon the number of work stations shown on the generic floor plan. The electrical panels or sub-panels must include the future growth percentage after the furniture is installed.

Conduits, boxes and pull strings and cabling must be provided and installed as identified in Section J-3 and Section J-4, See additional Electrical requirements found in:

- a. SECTION J, item 4 – Enterprise Network Data Cabling & Electrical Requirements
- b. Communications Specifications (separate attachment)

Evidence Room / Evidence Receiving Area may have surface mounted electrical boxes and conduit on the solid masonry walls.

Sally port – provide power to operate the overhead garage door. The garage door needs to be operable from with-in the sally port, the communications room as well as at the pedestal on the outside the sally port located along the driveway entrance.

The LESSOR'S electrician shall make all required connections to a halo grounding system that will surround the building. The halo grounding system will be provided separately through Penna. State Police, Radio and Information Services Division.

Communications Room - Install a soft tone doorbell in the Communications Room to sound when each entrance is opened. The Visitor entrance shall have a distinctive tone to be able to determine when a visitor has entered the building. The employee entrance(s) need to be different than the visitor entrance. Facilities that have several employee entrances may use the same tone for each employee entrance. The visitor door tone must be able to be heard in all areas of the building in the event the communications room is not occupied. It is also required that the staff has the ability to shut off or silence all door bell tones for the entrance doors.

The LESSOR will be responsible to install an EMERGENCY GENERATOR that will provide power to permit the entire building to remain operational during a power outage. The generator must be capable to operate all radio functions, telephone operations, computers, heating, ventilation, air conditioning, water, sewer, electrical outlets, lighting and any other function that uses power for the building and parking areas. The LESSOR must maintain the generator throughout the lease and it MUST BE OPERATIONAL WHEN THE NEED ARISES. In the event the emergency generator does not operate during a power failure the landlord must provide an emergency phone number to contact a repair service. The service company performing the repairs complete the repairs to the generator with-in 6 hours of being contacted by State Police.

The generator is required to be setup to perform a NO LOAD TEST weekly every Tuesday between 9 AM and 11 AM. A remote indicator panel must be installed in the communications room to permit the station communications operator to document the NO LOAD TEST was conducted. A run clock and generator running indicator lamp is required to permit monitoring of the weekly NO LOAD TEST.

At least one time per year an annual LOAD TEST is required to be performed. This test must be performed by a technician skilled in the trade of generator maintenance, it must include an annual preventive maintenance inspection with test results provided to the station commander for record. When the State Police take occupancy of the building proof must be provided that a contract is in place to maintain the emergency generator.

The landlord must provide the initial tank of fuel to operate the Emergency Generator. After the LESSEE takes occupancy of the building future fuel will be provided by the State Police. Sight screening at the generator fuel storage is needed to protect from vandalism.

The LESSOR shall provide and install at least eight (8) CABLE TV outlets with-in the building. Locations that need an outlet include; Communications Room; Conference Room and Kitchen Area other locations to be determined by the Station Commander.

2- LIGHTING

Except where otherwise provided in the specifications, lighting shall be in accordance with the American Standard Practice of the Illuminating Engineering Society of North America, ASNI/IES #RP-1-1982 (Revision of ANS #A132.1-1973) or any later revision.

All lighting levels must meet all applicable codes. All areas shall be illuminated with four (4) tube recessed fluorescent fixtures with prismatic lenses. All light fixtures shall have energy efficient electronic ballast such as Advance #REL-4P32-TP or approved equal with a minimum ballast factor of 90%. Furnish and install a complete set of 32 watt maximum T-8 lamps with 4100K color temperature and 75 minimum CRI such as Osram Sylvania Octron T-8 F032/741 or approved equal. Replacement of bulbs shall meet the same specification and are the Lessor's responsibility to replace.

Areas designated to receive drywall ceilings shall have surface mounted fluorescent lighting fixtures installed.

Lights shall be controlled by motion sensors that will shut the lights off when a room is not occupied, control switches are required.

High density Storage Areas	-	Lights to be placed to provide the most lighting in the aisles as the shelving units are moved.
Office Automation	-	Deep cell parabolic lenses

Exterior Lighting	-	Provide 5 foot-candles of lighting (or as required by code) over the entire parking, driveways and impound areas. Controlled by automatic sensors to come on at dusk and shut off at dawn. Wiring must be underground. All lighting must be on the HOUSE EMERGENCY GENERATOR provided by the LESSOR.
Building Entrances	-	Automatically controlled, side or over door installations.
Flagpole	-	Dusk to dawn illumination.
Interior Lighting	-	All lighting must be on the HOUSE EMERGENCY GENERATOR provided by the LESSOR.
Exterior Sign	-	Both sides of sign need illumination (see signage section)

3 – TELECOMMUNICATIONS

A fenced area outside the building is required for communications equipment, propane tanks, emergency generator and a possible radio tower with a concrete base. The LESSOR is required to install a concrete pad for the required equipment. The Pa. State Police, Radio and Information Services Division (717-346-5365) must be consulted on the size and the location of the concrete pad, including any special items that need installed. A 4'-0" wide gate is permitted where a radio tower is not required. The LESSOR must arrange with the radio maintenance representative to provide guidance during construction at the site. The LESSOR is required to obtain all necessary approvals and permits for placement of a radio tower on the property. The LESSOR hereby waives any right to restoration of the Lessee's premises and hereby releases the Lessee from any obligation to remove the concrete pad or pylons.

A gate will need installed to the front of the area where a radio tower is needed. The space that is with-in the fenced area must have a vegetation barrier placed and river rock covering the barrier to prevent weed growth. The LESSOR is responsible to control and eliminate any weed growth during the lease.

The radio maintenance contractor will also install a halo grounding system around the perimeter of the building. **Coordination between the LESSOR and Radio Maintenance Contractor is required when the building foundation is being constructed to permit the halo grounding system to be installed at the same time. THE LESSOR MUST** notify the designated radio maintenance representative as well as the Pa. State Police, Radio and Information Services Division (717-346-5365) at least four (4) weeks prior to construction of the building foundation.

The LESSOR must notify Penna. State Police, Radio and Information Services Division at least three (3) working days in advance of having concrete poured for the Communication's Room and other related areas of the building. An inspection must be performed of the proposed conduit locations prior to pouring the concrete floor.

The Communications Room in most facilities will have furniture provided by State Police consisting of two work stations 16'-0" in length by 5'-0" in depth. The furniture will be placed against a 42" high wall facing the bullet resistant window. The partial wall is to accommodate the required outlets, telephone and data connections. Larger stations to receive three work stations will be approximately 23' in length, refer to the Radio Communications Specifications and sketch at the end of their section of the specifications for this facility.

New station construction or total renovation of existing facilities require phone cabling to be run in the open space between the ceiling tile and the gypsum board on the bottom of the roof trusses.

Refer to SECTION 4 – ENTERPRISE NETWORK DATA CABLING AND ELECTRICAL REQUIREMENTS for the required number of telephone locations to be provided by the LESSOR based upon the size designation of this facility.

NOTE: any reference to an EMERGENCY GENERATOR in the Communications Specifications must be included in the sizing and operation of the HOUSE EMERGENCY GENERATOR required to be provided by the LESSOR that will operate the entire facility. The small emergency generator provided by State Police is eliminated from this project.

The State Police will determine the number and locations of speakers for the Public Address System identified in the Communications Specifications, plan for 1 speaker for each 300 sq. ft. of space. The LESSOR must provide all necessary items to make the PA system operational.

TELECOMMUNICATIONS COMMUNICATIONS SPECIFICATIONS (updated 10/31/14)

Questions related to this section should be directed to Pennsylvania State Police, Telephone Systems Services Section by calling 717-540-5050.

GENERAL

1. The Landlord is responsible to provide the communications and electrical requirements of the communications/dispatch room and for the Phone/Server room for a new station facility or renovation of an existing station. The communications/dispatch room has an area 400 square feet minimum for a two console facility (16 by 25 feet) and may accommodate such equipment as radio control consoles, network computer terminal, printer, audio logging recorder, and other essential items necessary for communication functions. One 2 by 6 framed half wall, drywall finished, will be built to contain electrical and communication wiring as shown in the drawing. The Phone/Server room is typically 150 square feet and houses all the radio, voice, video, data communications racks and equipment. It also typically contains the site's demarcation point.
2. These specifications include associated conduit requirements for primary and emergency power for communications equipment, radio and telephone control lines, alarm functions, and other items required for facility security. The communications room will be connected to other areas of the building such as the telephone/server room and an external equipment shelter, which houses radio equipment as required.
3. The communications/dispatch room has two main distribution frames called the Electrical Main Distribution Frame (EMDF) and the Communications Main Distribution Frame (DMDF).
4. The DMDF and the EMDF will provide a distribution point for the electrical power and communications cabling supporting the communications equipment at the station. See attached drawing (or drawing will be provided at preconstruction meetings) for details relating to EMDF and DMDF specifications within the communications room.
5. Special communications/dispatch room requirements, not necessarily specified herein, shall be coordinated and approved by the Bureau of Information Technology representative at the pre-construction meeting. It is required that a Bureau of Information Technology representative verifies the conduit layout before the pouring of concrete in the communications/dispatch room. Therefore, the contractor shall notify the Bureau of Information Technology representative at least three working days in advance to arrange a date for on-site inspection.
6. Pull cords shall be provided in all conduit runs.

7. One class ABC fire extinguisher shall be located within the Communications/Dispatch Room. One class ABC fire extinguisher shall be located within the Telephone/Server Room.
8. All conduits shall meet the National Electrical Code (NEC) standard for the particular application being installed.
9. Additional circuits or other terminations shall not be made to the EMDF or the CMDF without prior written approval from the Bureau of Information Technology.

Communications/Dispatch Room Requirements:

CMDF:

1. Refer to Radio Telecommunications Specifications.

Telephone/Server Room Requirements:

1. Refer to Radio Telecommunications Specifications.

Communication Room Required Cabling and Outlet box locations:

1. Two telephone outlet boxes are required installed at each answering position, must have a 3/4" conduit from the box inside the wall extending to the Communications Box (C9) within the half wall.
 - A two answering position station will require a total of four telephone outlet boxes.
 - A three answering position station will require a total of six telephone outlet boxes.
2. Four Category 6 cables are required from each outlet box to terminate on the Phone/Server Room patch panel.
3. Termination of cables must be completed using Category 6 rated jacks RJ11 or RJ45 for telephone and two RJ45 for data (Refer to FM Data specifications).
4. All cables must be tested and properly numerically labeled and documented on the wiring print prior to the scheduled move day

Building Telephone Cabling Requirements:

1. Each telephone outlet box must have a 3/4" conduit from the box inside the wall extending above the ceiling level and have a pull string in it. Must be grouped with electrical outlets. All locations will be approved by the Bureau of Information Technology.
2. The LESSOR must provide a Category 6 cable to each outlet box (unless otherwise specified), and home-run to Phone/Server room and terminated on patch panels.
3. All locations will be pre-approved by the Bureau of Information Technology.
4. Termination of cables must be completed using Category 6 rated jacks. Labeled numerically.
5. Termination of cables in Phone/Server room on patch panel(s) and labeled numerically.
6. All cables must be tested and properly numerically labeled and documented on the wiring print prior to the scheduled move day.

The Landlord is responsible to provide, install and complete the following:

1. A 3/4 inch conduit from the box inside the wall extending above the ceiling level with pull string and grouped with electrical outlets.
2. Category 6 cable, home-run, from each outlet box to Phone/Server room.
3. Terminate cables within wall boxes using Category 6 rated jacks and label numerically.
4. Terminate cables in Phone/Server room on a patch panel and label numerically.
5. Test all cables, label, and document on the wiring print prior to the schedule move day.
6. In areas with existing walls surface mount conduit may be used.
7. Lobby Phone: As part of the facilities telephone system, there shall be a wall mounted telephone located in the lobby adjacent to the counter Recessed box and conduit are to be provided by the Landlord's contractor. Height and side clearances of this phone shall adhere to ADA requirements.

PUBLIC ADDRESS SPECIFICATIONS

House Speaker System to include: Public Address Amplifier as manufactured by University, Type 1800-40 or approved equal product. Speakers: Atlas/Soundolier, Type SV1-72K, Model SD with volume control or approved equal product. The Public Address amplifier shall be installed on a shelf secured to the telephone equipment board, at the upper right corner. The associated speakers shall be equipped and wired for 70.7 volt operation with the speaker cable terminating on the telephone equipment board. Plan for one speaker for each 300 sq. ft. of space. The LESSOR must provide all necessary items to make the PA system operational. The Station Commander shall determine the recommended number and location of system speakers with the assistance of the Troop Communications Specialist.

Public Address Amplifier Minimum Specification:

- a. Power Output (RMS @ 1000 Hz) 40 Watts minimum
- b. Frequency Response 100 Hz – 12KHz + 2 Db
- c. Sensitivity Aux. 1 – 150 Mv
Aux. 2 – 150 Mv
- d. Hum + Noise Aux. 1 & 2, -70 Db
- e. Inputs Two, 600 Ohms Balanced
- f. Outputs 8, 16 Ohms, 25V Center Tapped
(18 Ohms) & 70V (140 Ohms)
Balance Lines
- g. Controls Aux. 1, Aux. 2, Master Volume, Tone Control
- h. Power Requirements 120 VAC 60 Hz

NOTE: If the amplifier does not have 600 Ohm balanced inputs, it shall be achieved by utilizing adapters manufactured specifically for the unit.

4 - ENTERPRISE NETWORK DATA CABLING & ELECTRICAL REQUIREMENTS updated 10/20/14

This specification will provide the LESSOR with the requirements for Pennsylvania State Police Enterprise Network Data cabling. The chart below is the **minimum number** of data and telephone locations required for the specific sized facility. The totals include the additional data locations for Megan’s law.

Examples:

FACILITY SIZE	Telephone Conduits	Enterprise Conduits & Cable
Small facility	(65)	plus (75)
Medium facility	(80)	plus (85)
Large facility	(120)	plus (130)
Extra Large Facility	(140)	plus (150)

Refer to the **QUANTITY SUMMARY** to determine the size standard of this facility.

Conduits must have boxes and pull strings provided for the enterprise network.

The actual number of data drops installed in a Pennsylvania State Police facility will vary depending on individual station requirements.

DATA CABLING STANDARDS

All data cabling must be CAT6 industry standards. It is the responsibility of the contractor to provide all cabling, keystones, faceplates, and CAT6 patch panels.

All data cabling runs must be tested and a copy of the test results forwarded to: Robert Flynn
717-772-0894 EMAIL roflynn@pa.gov

The results for data cabling test results show the ACR for each data run.

ACR

The first thing to understand about testing data cables is the ACR, this stands for **A**ttenuation to **C**rosstalk **R**atio. The pink area in the graph is the attenuation, this can be caused by several things as will be explained below, and the blue area is the crosstalk. Attenuation is the reduction in signal strength over the length of the cable and frequency range, the crosstalk is the external noise that is introduced into the cable. So, if the two areas meet, the data signal will be lost because the crosstalk noise will be at the same level as the attenuated signal.

ACR is the most important result when testing a link because it represents the overall performance of the cable.

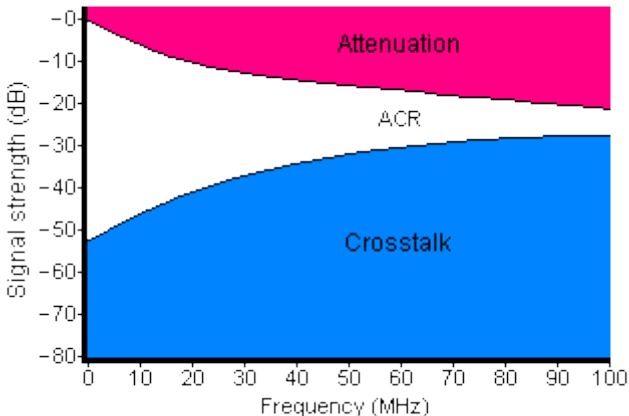

Test results should be sent to: Pennsylvania State Police, Bureau of Information Technology;
Information Technology Services Division
Attn: Robert Flynn
1800 Elmerton Ave.
Harrisburg, Pa., 17110

A unique PA State Police requirement will be that all Category 6 data jacks must be ORANGE in color. Non data jacks (voice) must be a different color. Each data drop faceplate must be affixed with a clearly readable numbered label to correspond with the LAN cabinet patch panel numbering scheme.

Data and Telephone may share the same conduit. (approved by Bob Flynn 10/16/14)

LAN/SERVER CABINET ROOM REQUIREMENTS

It will be the responsibility of the LESSOR to provide AC power and grounding for the LAN and Server cabinets. There must be a four (4) dedicated 120 volt, 20 amp circuits. The assigned circuit breaker must be clearly marked in the circuit breaker panel.

Data cabling must enter the LAN cabinet from above. Data cables (category six UTP cables) must enter the cabinet via a four inch EMT conduit. A hole must be cut in the ceiling tile to allow this conduit to extend above the ceiling tile. The same is true for AC power and ground but in this case a ¾ inch or one inch conduit will be used.

The SERVER/LAN cabinet is a standard 42U server rack, having a front door and split rear doors. The size of the server is 78"H x 24"W x 48"D.

New facilities are **planned to be constructed without basements**, however in the event a basement is present in an existing facility the SERVER/LAN cabinet must be on a raised platform to prevent water damage. The LESSOR must provide a platform to support the weight of the cabinet(s) with a ¾" plywood surface. The size of the platform is at least 33" deep x 57" long with a 2 inch by 6 inch base and not fastened tight to the floor to allow for movement.



ELECTRICAL SYSTEM CRITERIA AND COMPONENTS

Electrical services shall be provided as required by the LESSEE, to be determined in addition to code requirements. All material used in these installations shall be new and shall be installed in conformance with the requirements of the National Electrical code, the National Board of Fire Underwriters, the Pennsylvania Department of Labor and Industry and any other governmental or local authority having jurisdiction.

All isolated ground circuits shall be established by connection of an insulated ground wire from the isolated ground receptacle to the distribution panel for that circuit or by connection of an insulated ground wire to a suitable grounding source independent of other electrical circuits e.g. to building steel structure or a grounding rod furnished for this purpose. The intent is to avoid the possibility of fault currents from other pieces of equipment being able to interfere with or damage electronic processing equipment by conductance of fault currents through the isolated ground receptacle.

The surge suppression system shall be capable of intercepting and limiting transient voltage spikes caused by natural events e.g. lightning or other equipment operating on the power distribution lines. The contractor may choose whether this is best accomplished by individual circuits surge suppression or by circuit distribution panel surge suppression. All circuits shall have surge suppression whether normally grounded circuits or isolated ground circuits.

All electrical services and installation shall meet the current codes for new construction of the regulating jurisdictions. In no event shall grand fathering of existing services or installations be allowed. Electrical outlets shall be located through the use of receptacle panels, and/or wall outlets as approved by LESSEE. No electrical facilities shall be run through floor channel unless approved by LESSEE.

The LESSOR shall supply 115V, 20A, 60Hz, identified isolated ground circuits to work stations in the following circuit configuration.

- (A) No more than FOUR (4) personal Computers per 20 amp circuit.
- (B) No more than TWO (2) laser printer per 20 amp circuit.
- (C) No more than ONE (1) multi-function copier, scanner, fax unit per 20 amp circuit
- (D) No more than FOUR (4) utility receptacles per 20 amp circuit.

Each workstation will be required to have separate AC outlet. ONE circuit reserved for the personal computer and monitor. A SECOND circuit is for general utilities example for office equipment. The outlet assigned to the personal computer must have a separate AC neutral and isolated ground wires. The circuits for the personal computer shall have **a single orange outlet** and the circuits where the designated laser printers are located should **have a single blue outlet**. The circuit for general utilities should have a minimum of two (2) duplex outlets at each workstation, in addition to the outlet for the computer and monitor.

The Processing Room must have at least eight (8) Enterprise Network locations provided, two (2) for the LIVESCAN equipment, two (2) for the photo imaging equipment, one (1) for Megan's law equipment, one (1) for Video Conferencing equipment and two (2) for future Enterprise Network needs. Associated electrical requirements must be met for this equipment.

The PSP Enterprise Network staff will need several data sites located on the exterior wall of the building near the roof. Placement will need to be near the state vehicle parking areas to allow PSP staff to mount small antennas on the building for the Mobile Video Recorder (MVR) equipment.

GENERAL INFORMATION

When a move from an old station to a new station occurs the primary goal is to minimize the downtime of the PSP Enterprise Network. It is especially critical to restore service to the Communications Room terminals in particular as they have a direct bearing on both public and officer safety. It cannot be stressed strongly enough that on the day the move occurs the lessor must have accomplished the following goals prior to the date of the move:

1. All data drops in the building must be installed and tested prior to the moving date.
2. The (4) 20 amp circuits must be installed and operational prior to the moving date. (SAME CIRCUITS AS IDENTIFIED IN THE ELECTRICAL SECTION IN THE SERVER/PHONE ROOM)

At the same time that data cabling is being punched down PSP personnel and telephone company personnel will likely be working in the cabinets to install the FRAME RELAY, ISDN and POTS lines required to connect the new location to the network.

SECTION K - MECHANICAL SYSTEM CRITERIA

1 - HEATING, VENTILATION & AIR CONDITIONING (HVAC)

All areas are to be heated, ventilated and cooled except the following areas with requirements as noted:

Storage Area, Sally port and Mechanical Room - Heated and ventilated only

The Lessor / contractor shall perform and provide complete engineering and construction of a **GROUND SOURCE HEATING AND COOLING SYSTEM** for this facility. The entire Mechanical and Plumbing system in all and / or in part shall conform to all pertinent laws, ordinances, and regulations of all bodies having jurisdiction. Comply with applicable codes, rules regulations, and building safety laws relating to construction, public health and safety.

The only permitted alternate to a GROUND SOURCE HEATING AND COLING SYSTEM IS NATURAL GAS THAT IS DELIVERED TO THE SITE BY A BURIED RIDGID PIPE CONNECTED TO A MAIN GAS SUPPLY AND WILL BE USED AS THE PRIMARY SOURCE OF FUEL.

The following WILL NOT BE PERMITTED as a primary source of fuel:

- a. PROPANE GAS
- b. FUEL OIL
- c. ELECTRIC HEAT PUMPS
- d. COMPRESSED NATURAL GAS

The HVAC system must be sized for a 25% capacity increase.

The Lessor / Contractor shall supply all documentation regarding the engineering design, construction and operation to the Lease.

The server room space is to have its own climate controlled HVAC system capable of maintaining a space temperature of 68 to 75 degrees **at all times and in all conditions.**

This system will be inaugurated with the building Geo-Thermal system and have its own air handler and thermostat.

Consideration will be given to the amount of heat gain that is given off by the equipment. This is to be done by either oversizing the returns or by exhausting the air. In the following areas:

- 1. Processing Room
- 2. Telephone / Server Room
- 3. Communications Room

The following is an estimate of the equipment planned for several areas where equipment produces heat.

The Processing Room equipment and the BTU output:

- Live Scan System – Includes computer tower, printer and monitor – (6990.5 BTU/hr)
- CPIN System – Includes computer tower, printer, monitor, camera and lights – (12617 BTU/Hr)
- Regular Computer System – Includes computer tower and 2 monitors – (3069 BTU/Hr)
- Total – 22676.5 BTU/Hr

Total does not include recently installed computer equipment for Megan’s Law. LESSOR will need to visit the station to determine the added BTU/Hr for this equipment

The Telephone /Server Room equipment and BTU output:

IBM X3650 – Heat Dissipation 1230-3312 BTU/hr times 2.

UPS s – SUA1500times 2 (Watts [BTU/hour]

On Line Fully Charged 45 [135]

On Line Charging 75 [255]

On Battery Fully Charged 315 [1075]

Cisco 3745 Router

Heat Dissipation + 2013.257 BTU/hr. x 1

Cisco 3560 Switch

Heat Dissipation = 89 BTU/hr. x 6 Total = 534 BTU/hr.

The LESSOR will be required to provide additional cooling and / or ventilation at no additional cost to the State Police to prevent the new equipment and all future equipment from over heating.

Evidence Room, Evidence Receiving Area - All duct work that is large enough to permit a person to climb through must have security bars installed to prevent intrusion through the ducts. Security bars will need placed at the perimeter of the Evidence Area which includes the Evidence Receiving.

1.1 -TEMPERATURES

A temperature of 73 degrees F dry bulb + /- 2 degrees F dry bulb shall be maintained under all conditions.

1.2 - HUMIDITY

Humidity shall be maintained between 40% and 60% relative humidity in all areas that are mechanically cooled and heated. If required to meet the conditions, power humidifier installed in the central system shall be employed. No supplemental humidification need be provided in areas not mechanically cooled. Reduction of humidity levels will not be allowed to compensate for an inadequate building ventilation system.

1.3-VENTILATION

All ventilation will meet the recommendations of the American Society of Heating, Refrigeration and Air Conditioning Engineers (ASHRAE) Standard 62, current revision. The current revision requires the introduction of at least 20 cfm outside air per person in all office areas. All air intakes shall be located to preclude the introduction of exhaust air from all exhaust air sources. The fresh air intakes must be positioned at the highest locations practical with none at grade level. Intake locations should not be placed near vehicle idling areas such as the sally port or garage entrance. Use of an economizer package allowing up to 100% outside air is acceptable provided all other conditions of temperature and humidity are met. Return ducts to be installed at floor level NO PLENUM CEILING.

Several areas of the facility will require direct exhaust to the exterior of the building and be isolated from the general ventilation system: Restrooms, Shower Areas, Kitchen, Processing Room at restraint bench, Patrol Unit at the restraint bench, Crime Room at restraint bench, Interview Room, Evidence Room, Evidence Drug Closet, Motor Carrier Enforcement Office and Arms Closet. Facilities that have an area designated for a K-9 will also require an exhaust. The exhausts fans near prisoner restraint benches and the interview room shall have manual controls.

An on demand power ventilation system is required in the Evidence Room and Drug Closet. The system shall be operational from a lighted wall switch in the Evidence Receiving Area. The switch shall have an indicator light that will light when the system is operational.

The Telephone / Server Room that houses the server for the Enterprise Network must be properly ventilated to accommodate the equipment to be installed.

1.4 - FILTRATION

All areas serviced by heating or air conditioning or ventilation systems will have Polyester Medium Pleated pre-filters of at least 2" minimum thickness installed in that system. The filter shall have a MERV (Minimum Efficiency Reporting Value) rating value of (8) or greater when tested by an independent test facility according to ASHRAE (American Society of Heating, Refrigeration and Air Conditioning Engineers) Standard 52.2. The filter will be a standard dust holding capacity model that a 24" x 24" x 2" filter will have no less than 12.4 square feet of media. The air filter manufacture's literature/technical sales bulletin must show that the model provided is 76% efficient or greater on 3.0-micron size particles. The pre-filter will be installed in the system at a place that will filter air handled by the system before distribution into the work areas or public area. The LESSOR on a monthly schedule or more often must replace all filters, if required by operating conditions. During replacement operations, the system will be completely shut off to avoid the distribution of dirt through the system.

1.5 - PRESSURE DIFFERENTIALS

Storage and garage areas shall maintain a negative pressure differential relative to adjacent areas to control the migration of fumes or odors. The pressure maintained in the building shall be positive relative to the outside to prevent the infiltration of air.

1.6 - HVAC CONTROLS

The building shall be controlled totally automatically. Thermostats and other automatic controls shall be inaccessible to employees. Manual controls of heating, ventilating, cooling or humidifying equipment are not acceptable except for an EMERGENCY SHUTDOWN SWITCH OR CONTROL that allows for immediate shutdown of the HVAC System. In addition, the building shall be appropriately zoned with automatic controls to maintain even HVAC throughout the area regardless of the anticipated use of the areas. Areas having concentrations of heat-producing equipment shall be adequately addressed in the HVAC zoning i.e. Communications Room, Phone / Server Area and Processing Room which may require a stand-alone system to provide sufficient cooling.

2 - PLUMBING / UTILITIES

All plumbing and utilities shall meet the current plumbing and building codes of the municipality within which the facility is located. In no instance will grand fathering of nonconforming plumbing or utilities be allowed. ALL PLUMBING AND UTILITIES SHALL MEET CODES AS DESIGNATED FOR NEW CONSTRUCTION.

All domestic hot water supply shall be located not more than 35 feet from furthest point of use, it shall have the most energy efficient models available. All sinks, lavatories, and showers shall have hot water available. All water heaters shall initially be set at 120 degrees F.

Hot and cold water lines shall have insulation applied. Supply water lines (hot and cold) shall be type "L" copper or PEX. The use of lead solder shall not be used as mandated by Legislation.

In addition to the hot, cold and waste water systems required by code, the LESSOR shall provide floor drains in the following locations:

- At the safety shower in the Sally port
- Under vehicle in the Sally port – designed for sediment removal from vehicle (ice/snow)
- In the floor of Patrol & Crime at the restraint bench location(s)
- In the floor of the Processing Room near the restraint bench
- In the floor of the Public Restroom
- In the floor of the Restroom near Processing
- In the Shower Area of the Men's and Women's Restroom / Locker Room
- In the floor of the Storage Room
- Interview Room where designated on the floor plan
- R & I Unit

As otherwise required to support specific laboratory or operational requirements

Floor drains near any restraint bench require tamper proof screws to hold the drain screen in place.

Install two (2) exterior frost proof faucets, one (1) near the storage entrance, the other near the main entrance. Provide two-(2) water coolers meeting ADA guidelines, one (1) in the Lobby the other in the Troop Area.

Provide at least one (1) shower in each locker room that complies with (ADA) guidelines. All showers require curtains. Shower heads shall be water saving units.

Hose bibs located with-in an enclosed compartment will need provided in close proximity to areas where restraint benches are proposed.

Facilities that require a sewage pump station should have a minimum 2 horse power grinder pump installed to prevent backups

3- ELEVATORS (where required)

One elevator must have inside dimensions of not less than 6'8" x 5'5" with not less than 36" door opening, if elevators are required by code unless otherwise approved by Lessee. If elevator exists, they are to be modernized to provide automatic operation and to bring equipment into compliance with the Americans with Disabilities Act. The Elevator Contractor must be an elevator manufacturer or manufacturer's approved installer. Acceptable manufacturers are Otis elevator Company Cemcolift or Minnesota Elevator, or Lessee approved equal.

Licensed and permits shall be provided and the required inspections and tests shall be performed. Elevators shall comply with applicable building and elevator codes, included but not limited to the following:

- ANSI A17.3
- ANSI A17.1
- National Electrical Code
- Pa Department of Labor and Industry Elevator Regulations
- Americans with Disabilities
- Uniform Federal Accessibility Standards

Existing elevators are modernized with the following standards as approved by the Lessee:

- A minimum standard speed of 100 FPM
- All In-Ground Hydraulic cylinders shall be incased in PVC liners. If the owner can not prove the cylinder is encased, it shall be removed and replaced with a sealed unit or an above ground system.
- All elevators over two stories shall be equipped with over speed governor and safety mechanisms capable of stopping a fully loaded car an over speed condition.
- If elevator does not meet handicap guidelines, it shall be modernized with the following criteria in mind:

Controller shall be relay-logic or non-proprietary microprocessor based controller. Complete electrical diagrams shall be provided to LESSOR including all straight line prints, electronic circuitry and microprocessor logic diagrams. If a programming tool and software is needed to trouble shoot or adjust elevator, it shall be provided with the control system at no extra charge. Microprocessor shall be an "off the shelf" industrial type controller, readily available on the open market.

Components such as door operator, selector, buttons etc. shall be able to be replaced and upgraded independent of the elevator controller.

LESSOR must demonstrate that all components are the most energy efficient available. When full elevator replacement or new construction is needed, buildings over four floors in height should view traction elevators as the most desired type of equipment.

The modernization shall include complete operation and control systems, new door operators, car operating stations, hall button fixtures, new cab and hoist way doors, complete cab modernization and various adjustments, safety test and related repairs.

SECTION L - FINISHED GRADING & SEEDING

1 - FINISHED GRADING & SEEDING

- 1.1 Finished grading shall eliminate low spots where water would be expected to accumulate.
- 1.2 All rocks and debris in excess of 1" shall be removed.
- 1.3 The soil shall be fertilized, tilled, seeded and mulched.
- 1.4 Lawn seed and mixtures shall consist of the following:

Permanent Lawn Seed Variety	% Parts	% Purity	% Germination
Kentucky Bluegrass	45	95	85
Pennlawn Fescue	45	85	75
Perennial Ryegrass	10	95	85

- 1.5 Seeding shall be 5 lbs. per 1000 sq. ft. Planting shall occur between August 20 and October 1 or where spring seeding is necessary before May 15.
- 1.6 Lawn shall be kept constantly wet close to saturation for 10 days following seeding.
- 1.7 If the grass seed does not germinate the lessor shall be responsible to reseed the areas.

2 - LANDSCAPING

- 2.1 **DO NOT PLANT shrubbery and trees along the exterior walls of the building because as the plants grow it creates a visual obstruction and a security risk to the staff.** A Variance from the municipality may be necessary. The facility is required to have a security monitoring system to observe the building entrances and parking areas.
- 2.2 The Lessor shall have the option of providing either:
- (a) The LESSOR shall provide grass around the entire perimeter of the building with no separation between the grass and the building.
- b) Install a concrete sidewalk approximately 2'6" - 3' wide along the front and both sides of the building beneath the roof overhang. The side of the building where access to the mechanical room / server room may have grass planted up to the building as well as along the rear wall of the building. (See Generic Site Plan for guidance)
- 2.3 A station that requires a radio tower shall have the fenced area surrounding the radio tower and the concrete pad with the emergency generator, propane tanks. This area must have a vegetation barrier installed and covered with river rock. **The LESSOR is responsible to prevent and eliminate any weed growth in all beds of river rock during the building occupancy.**

SECTION M - MISCELLANEOUS CONSIDERATIONS

1. Furnish and install two (2) 35 foot flagpoles. One pole will display the Federal Flag while the second displays the Commonwealth Flag.
2. Furnish and install a 30" diameter plaque consisting of the State Seal with Pennsylvania State Police information bordering on the Seal. The plaque which shall be cast aluminum and painted in accordance with State colors, as proposed by Spencer Industries, 1508 North Mascher Street, Philadelphia, Pennsylvania (215) 634-2700 or Lake Shore Market, Inc., 654 West 19th Street, Box 59, Erie, Pennsylvania (814) 456-4277.
3. The Kitchenette shall have the following appliances; a microwave, refrigerator (full size), base counter cabinets and wall cabinets, with **double stainless steel sink** and paper towel dispenser.
Stoves will not be permitted to be installed in leased buildings as stated in Management Directive 720.5 as amended January 3, 2008 non compliance will result in rent abatement.
4. The Crime Unit - The Lessor shall provide and install a forms / mail bin rack. The number of slots and the size shall be determined by the Station Commander. (Refer to Detail drawing sheet)
5. The Patrol Unit – The Lessor shall provide and install a forms /mail bin rack. The number of storage bins and the size will need determined based upon the number staff assigned to the station and the number of forms being used. The LESSOR shall construct an area in the Patrol Room to display clipboards. It will be determined prior to construction of the station if funding will be available for furniture that will take the place of a counter. In case funding is not available for work stations. The LESSOR will need to install a typewriter counter approx. 20' in length, 28" from the floor to the top of the counter. The counter will have holes installed to permit cords to pass through the counter to electrical outlets, phone and data sites. Lighting will need provided above the counter.
6. Install in each lavatory and locker room, an automatic aerosol odor control as manufactured by Airken Professional Products. System shall be self dispensing by a timed metering system in intervals of 5 - 25 minutes. System maintenance and replacement of odor control supplies will be the responsibility of the lessor.

7. Facilities that remain occupied during renovations must have debris and waste materials of every description removed from the area and a general clean-up after every days work.
8. Prior to occupancy of the facility, LESSOR shall provide LESSEE, with current certificates of insurance. The certificates shall contain a provision that the coverage afforded under the policies will not be canceled or changed until at least thirty (30) days written notice has been given to LESSEE.
9. Provide a cork bulletin board, minimum size being 36" x 60" in the Communications Room at a location to be determined by the Station Officer-In-Charge.
10. Install a soft tone doorbell in the Communications Room to sound when each entrance is opened. Visitor entrance shall have a distinctive tone to be able to determine when a visitor has entered the building. The employee entrance(s) need to be different than the visitor entrance. Facilities that have several employee entrances may use the same tone for each employee entrance. The visitor door tone must be able to be heard in all areas of the building in the event the communications room is not occupied. It is also required that the staff has the ability to shut off or silence all door bell tones for the entrance doors.
11. All construction, existing or new, must be in full compliance with the Americans with Disabilities Act (ADA) whether or not specifically mentioned in the specifications or depicted on the drawings.
12. Pollution control as mandated by the Department of Environmental Resources. The LESSOR shall be responsible to correct any environmental hazards that may be present at the time of occupancy or could be incurred during the term of the lease. The LESSOR shall bear the financial responsibility to correct any hazards that are not created by the LESSEE.
13. The LESSOR shall have performed and submit regularly as required the results of a water test from a reputable laboratory where a public water service system is not available to the facility.
14. LESSOR shall have building plans approved by the Department of Labor and Industry. The lessor shall also furnish a copy of the Certificate of Occupancy, issued by Labor and Industry or the municipality to the Pennsylvania State Police, Facility Management Division, at the time of occupancy of the facility.
15. All construction must be completed and all contractors finished with their work before occupancy of the building or increase of any rental payments to the LESSOR. If not the LESSOR will be responsible for payments of the present lease rental until the facility can be occupied. Existing construction requires renovations to be completed prior to receiving the increased rental rate at the renovated facility, all renovations must be satisfactorily completed.
16. LESSOR shall supply to the LESSEE the names of plumber, electrician and heating and ventilating contractors who can be contacted in case of and emergency.
17. During the lease term or in preparation to enter an option period where floor covering material is being replaced or cleaned, painting or cleaning of walls are required. The LESSOR at their expense will be required to remove and replace the existing furniture, file cabinets and other equipment to perform the required work.
18. The LESSOR shall mount Armor Piercing Containment System APC-100 (provided by PSP) at several locations with in the building as determined by the Officer in Charge.
19. All building systems and components that are provided by the LESSOR at the facility shall be maintained by the LESSOR during the lease and any option periods that are exercised.

20. The LESSOR is responsible for all costs related to the extermination of insects, bees, rodents etc. and must maintain the PREMISES in tenantable condition.
21. The LESSOR must provide and install all observation mirrors and security cameras located in the lobby to permit the communications room staff seated at the radio consoles to see the entire lobby.
22. The Lessor is to provide and install at least 4 wall mounted coat racks, 1 near the conference room, 1 near the crime office, 1 near the patrol office and 1 in Drug Law Enforcement. Each office shall have a coat hook installed on the door on the inside of the office.
23. All requested changes to the specifications must be submitted in writing and shall not be changed unless **WRITTEN** approval is granted by the Director, Bureau of Staff Services, Pennsylvania State Police.

SECTION N – QUANTITY SUMMARY:

The following is a list of items that require a quantity to be provided by the LESSOR as a part of the State Police facility lease. Each item is described in greater detail in the General Specifications & Space Design Criteria.

Items # 9 -13 address the date of the specifications and building plans that are part of this bid package.

1. __168__ Total number of parking spaces.(refer to generic site plan)
2. __26__ Parking spaces in the impound area, or __15,440__ square feet.
3. __6__ Parking spaces meeting Americans with disabilities, includes __3__ van accessible spaces.
4. __600__ Total linear feet of high density shelving for evidence storage required in the new evidence room. The width of the existing shelving is 2'-0" wide and must be the width used in calculating the proposed linear feet of shelf space.
5. __116__ Total number of lockers required (refer to generic floor plan for placement in each locker room)
6. The men's locker room must have 101 lockers which shall match the number of briefcases that need accommodated in brief case racks.
7. The women's locker room must have 15 lockers which shall match the number of briefcases that need accommodated in briefcase racks.
8. This facility is considered an **EXTRA LARGE** sized facility.
9. Pennsylvania State Police, General Specifications & Space Design Criteria dated __1-5-2015__ (including map of advertised area)
10. Pennsylvania State Police, Communications Specifications dated 11/08/14.
11. Generic Floor plan for the _York Station, dated __7-22-2014__
12. Generic Site Plan, dated _7-22-2014_
13. Detail Sheet, dated_4-23-2009_ with Revision dated 5/25/2011

ATTENTION !

ALL PERSONS SUBMITTING A PROPOSAL, THIS “SOLICITATION FOR PROPOSAL” HAS A SET OF DRAWINGS (FLOOR PLANS) THAT MUST BE OBTAINED FROM THE BUREAU REAL ESTATE BY CALLING 717-783-0829 OR 717-787-4394.



END OF SPECIFICATIONS

Pennsylvania State Police
York Station
Communications Specifications
Date - 110814

GENERAL

1. The CMDF and the EMDF will provide a distribution point for the electrical power and communications cabling supporting the communications equipment at the station. See attached drawing (or drawings will be provided at preconstruction meetings) for details relating to EMDF and CMDF specifications within the communications room.
2. Special communications/dispatch room requirements, not necessarily specified herein, shall be coordinated and approved by the BCIS representative at the pre-construction meeting. It is required that a BCIS representative verifies the conduit layout before the pouring of concrete in the communications/dispatch room. Therefore, the contractor shall notify the BCIS representative at least three working days in advance to arrange a date for on-site inspection.
3. All conduits shall meet the National Electrical Code (NEC) standard for the particular application being installed.
4. The Emergency Generator shall provide power for all outlets and lights located in the communications room and server room. In addition, the Eventide, if it is located in the server rack, shall be on UPS. Two 3 inch conduit shall be run from the mechanical room transfer panel to the generator for power and control.

Communications/Dispatch Room Requirements:

EMDF:

The EMDF shall accommodate primary/emergency power and circuit breaker requirements for communications equipment only. Other electrical outlets in the communications/dispatch room shall not be connected to the power supplied by the EMDF.

1. The EMDF panel shall have the capacity for at least forty 20 AMP circuit breakers. The panel housing shall be flush mounted adjacent to the CMDF panel and shall be provided with a hinged cover. All circuit breakers shall be legibly identified.
2. A 3 inch conduit shall be provided between the EMDF panel in the communications/dispatch room and the telephone/LAN room. All EMDF power must be on the same phase provided by the emergency power transfer switch.
3. A 3 inch conduit shall be provided between the EMDF and the mechanical room transfer panel.
4. Refer to the attached communications/dispatch room drawing for location and additional specifications on EMDF receptacles within the communications/dispatch room. All receptacles shall be wall mounted and marked as being on emergency power.

Pennsylvania State Police
York Station
Communications Specifications
Date - 110814

5. If an tower will be present, one 1 inch conduit will be run from the tower pad to the EMDF and contain one 20A circuit. One 3 inch conduit shall run from the server room to the tower pad.

CMDF:

1. The CMDF panel will provide a distribution point for all communications cabling and wiring within the communications/dispatch room.
2. 4" conduit(s) shall be provided between the CMDF panel and the telephone/server room. Conduit(s) will carry the radio control circuits from the outside equipment shelter and also the home run telephone lines from the telephone/server room to the communications/dispatch console.
3. The CMDF panel shall be a 30" x 20" x 6" empty distribution panel with a flush-mount hinged cover. This panel is contained in a metal enclosure similar to a Square D Cabinet Box # 24366B and a Front Cover # 2436TF. The rear surface of the panel shall be a 3/4" plywood backboard painted flat black.
4. Refer to the communications/dispatch room drawings for location and additional specifications on CMDF receptacles within the communications/dispatch room.

Radio Requirements:

1. To facilitate the radio system antenna mounting, two antenna mounts must be installed opposite ends of the building. Each mount will consist of a 2"OD thick walled galvanized pipe with a minimum length of 72" long. The pipe must be mounted to a roof truss to support the weight of the antenna(s). A 2 inch PVC conduit will pass through the wall within one foot of each mounted pipe and terminate in a 90 degree elbow outside (turned downward to prevent water intrusion) with a weatherproof seal. An alternative to the 90 degree elbow would be to put an electrical box similar to the Cantex model 5133708 (or equivalent) 8x8x7 Plastic New Work Electrical box mounted on the wall within one foot of the 72" pole with a 2 inch PVC pipe through the wall.
2. The antenna mounts must be attached to the building electrical ground system.
3. Contact the PSP radio maintenance service provider for appropriate locations of the antenna mounts.

Pennsylvania State Police
York Station
Communications Specifications
Date - 110814

Telephone/Server Room Requirements:

1. In order to facilitate installation of telephone and alarm control equipment, a telephone equipment panel, an 8' x 4' x 3/4" plywood panel, painted with flat black fire resistant paint, shall be wall-mounted in a room designated as the telephone/server room. The panel shall be installed horizontal with the bottom edge approximately 3.5' above the floor. A minimum of two (2) duplex electrical outlet boxes shall be mounted at the top of the panel, 2 feet from the left and right edge. In addition to the standard electrical requirements listed in the specifications two (2) additional electrical quad outlets shall be mounted along the bottom edge of the panel, 2 feet from the left and right edge, to be used for the station phone system and equipment and telephone company equipment. All electrical boxes mounted on this panel shall be wired to the Emergency Generator. Conduit from the floor of the telephone/server room shall extend at least six inches from floor level.
2. A #2 awg bare copper conductor shall be installed along the bottom edge of the panel and shall terminate on a ground rod positioned beneath the plywood panel. This rod shall be connected to the internal building grounding system and the external perimeter grounding system. This will serve as the one point connection between the two grounding systems. The Department's radio maintenance contractor shall provide the external perimeter grounding system and the concrete pad for the external radio equipment shelter; as well as, any required radio tower and associated material for tower erection.
3. Three 20A circuits will run into the server rack and four 20A circuits to two quad outlets will be run for radios.
4. One 3" conduit shall be provided between the telephone/server room and the external radio equipment shelter or tower pad to accommodate the communications cabling.

Communication Room Required Cabling and Outlet box locations

1. Thirteen Cat 6 cables (or equivalent) via 4" conduit from CMDF to telephone/lan room to be used as feed cables. Terminate on one 110 block at the CMDF and one 110 block at the telephone/lan room. Must be labeled FEED CABLES.
2. All cables must be tested and properly numerically labeled and documented on the wiring print prior to the scheduled move day.

York Station Communication Room

Date – 11/08/14

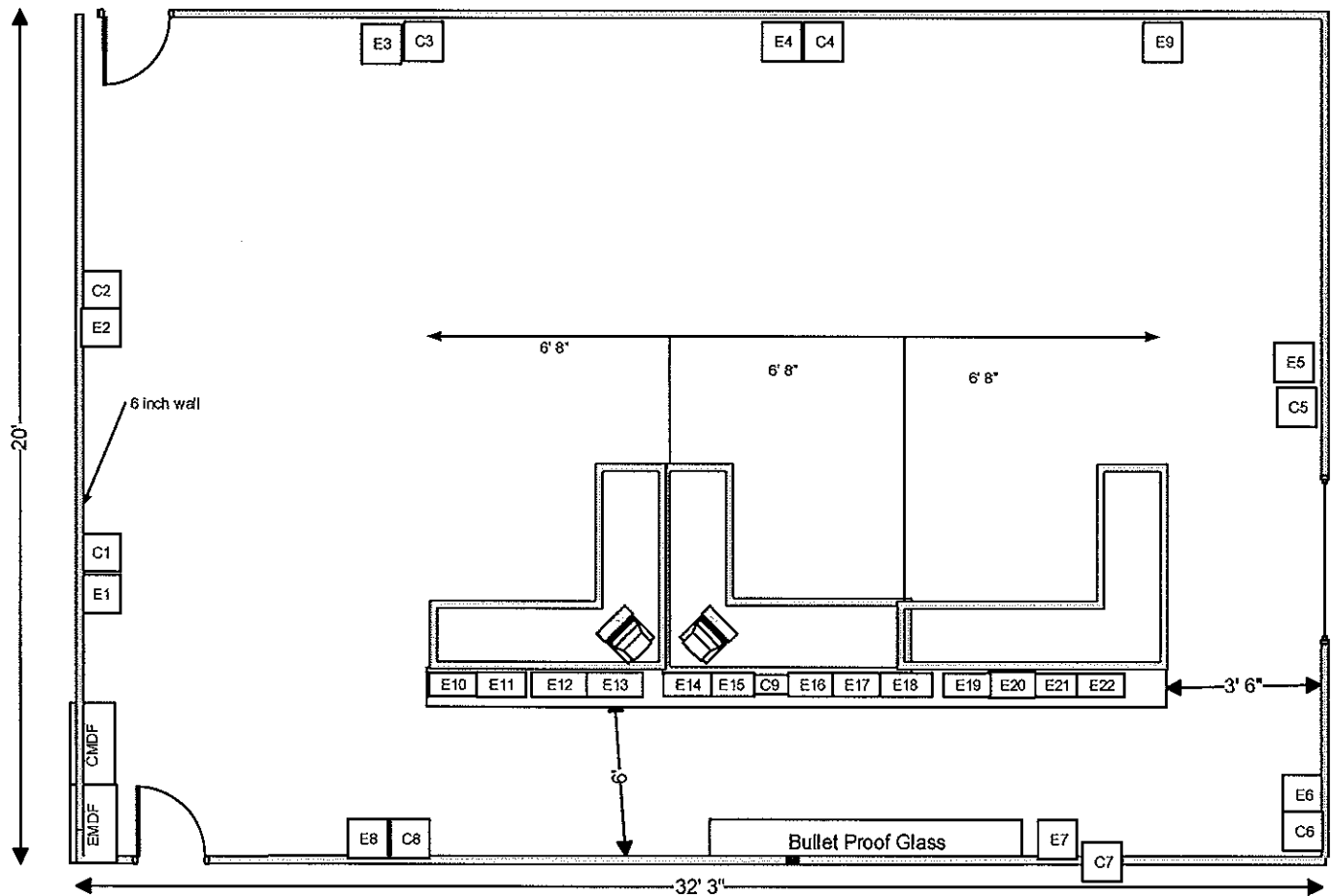

1. EMDF and CMDF panels shall be connected to the telephone/utility room via conduit.
2. EMDF receptacles shall be clearly marked indicating connection to emergency power.
3. Receptacles E1, E2, E3, E4, E5, and E7 shall be dual socket wall style outlets on individual 20 Amp circuit breakers in the EMDF.
4. Receptacles E6, E8, and E9 shall be quad socket wall style outlets on individual 20 Amp circuit breakers in the EMDF.
5. E6 and C6 will be mounted high on wall for TV. E1, C1, E2, C2, E3, C3, E4, C4, and E9 can be mounted high enough so that it will clear file cabinets. Discuss room layout before deciding outlet height.
6. E10 through E22 shall be a quad socket wall style outlet, one 20A circuit breakers per quad powered by the EMDF panel.
7. C1 through C8 shall be 3/4" conduit, C9 shall be 3" conduit to the CMDF.
8. E10 through E22 and C9 shall be inside a 20' long wall, 42" high. Wall will have removable back (side facing towards window) for rewiring access.
9. C7 shall be a thru wall conduit for lobby telephone/intercom.
10. Lobby exit lights, vestibule lights, and Communications Room overhead lights shall be connected to the emergency power provided by the EMDF panel.

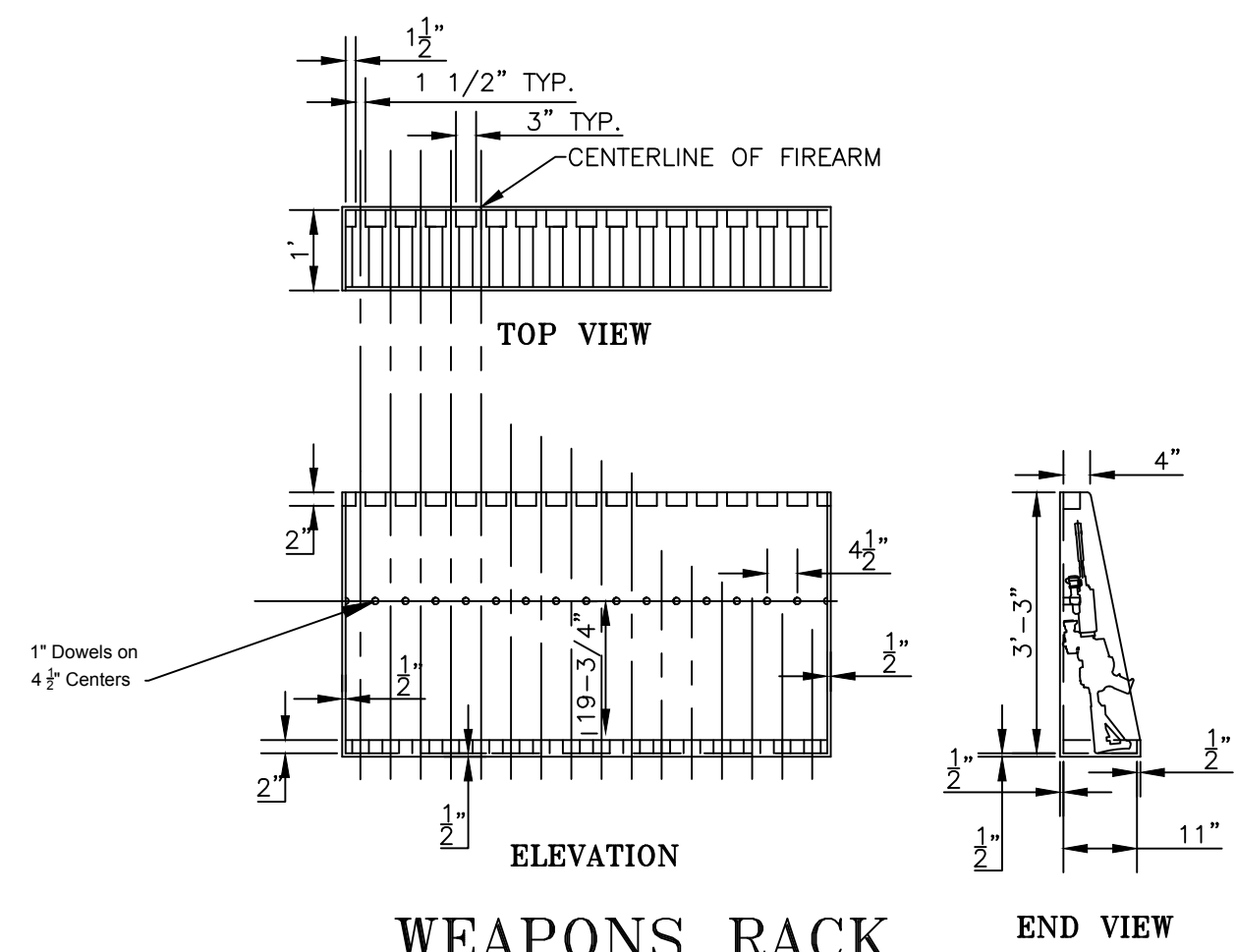

WEAPONS RACK

NOTE: THE SIZE OF THE GUN RACK SHALL VARY ACCORDING TO THE NUMBER OF FIRE ARM AT THE RESPECTIVE STATION
 * REVISED 5-25-11 to accommodate new issued patrol rifle and shotgun

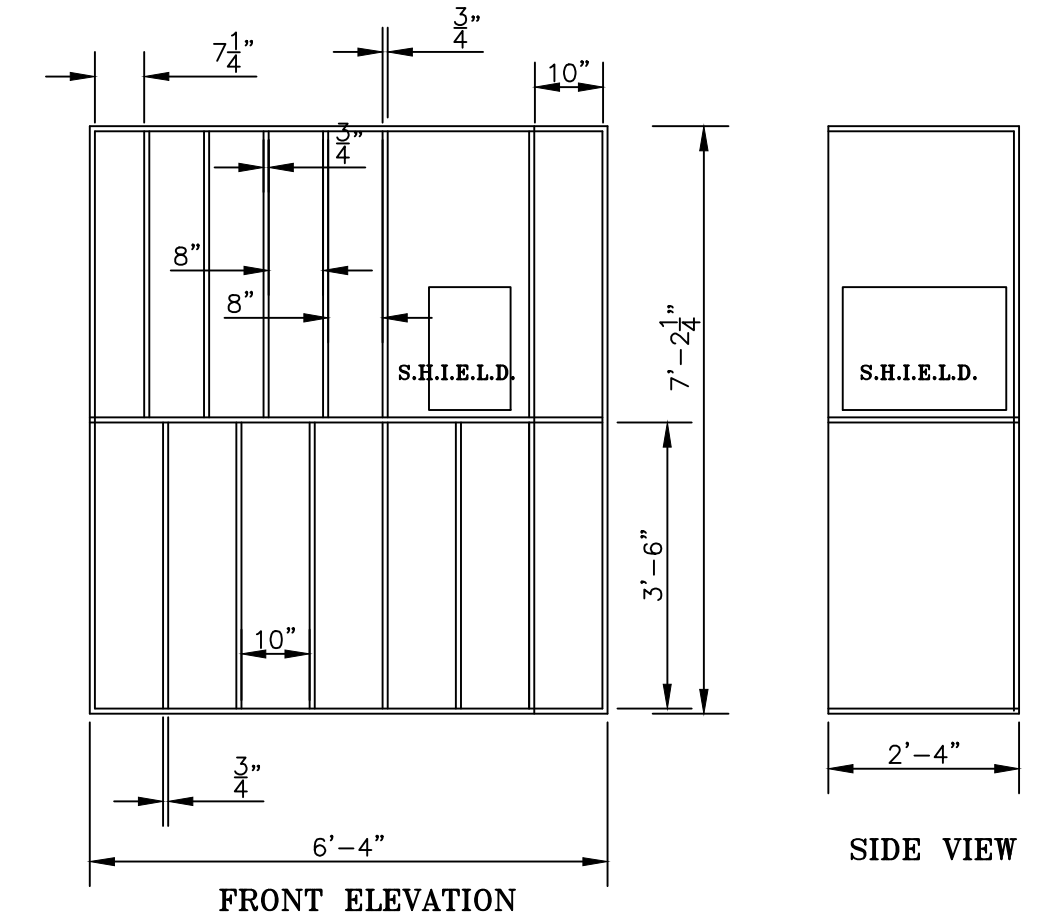

RIOT SHIELD STORAGE UNITS

THE LESSOR MUST VERIFY NUMBER & SIZES OF THE RIOT SHIELDS AND ADD SPACE FOR ADDITIONAL SHELVES. ANY ADDITIONAL COMPARTMENTS SHALL BE CONSTRUCTED TO ACCOMMODATE THE LARGER SIZE SHIELDS. ELECTRICAL OUTLETS ARE NEEDED NEARBY TO RECHARGE THE LIGHT PAKS ON THE NEWER RIOT SHIELDS. CONSTRUCTED WITH 3/4\"/>

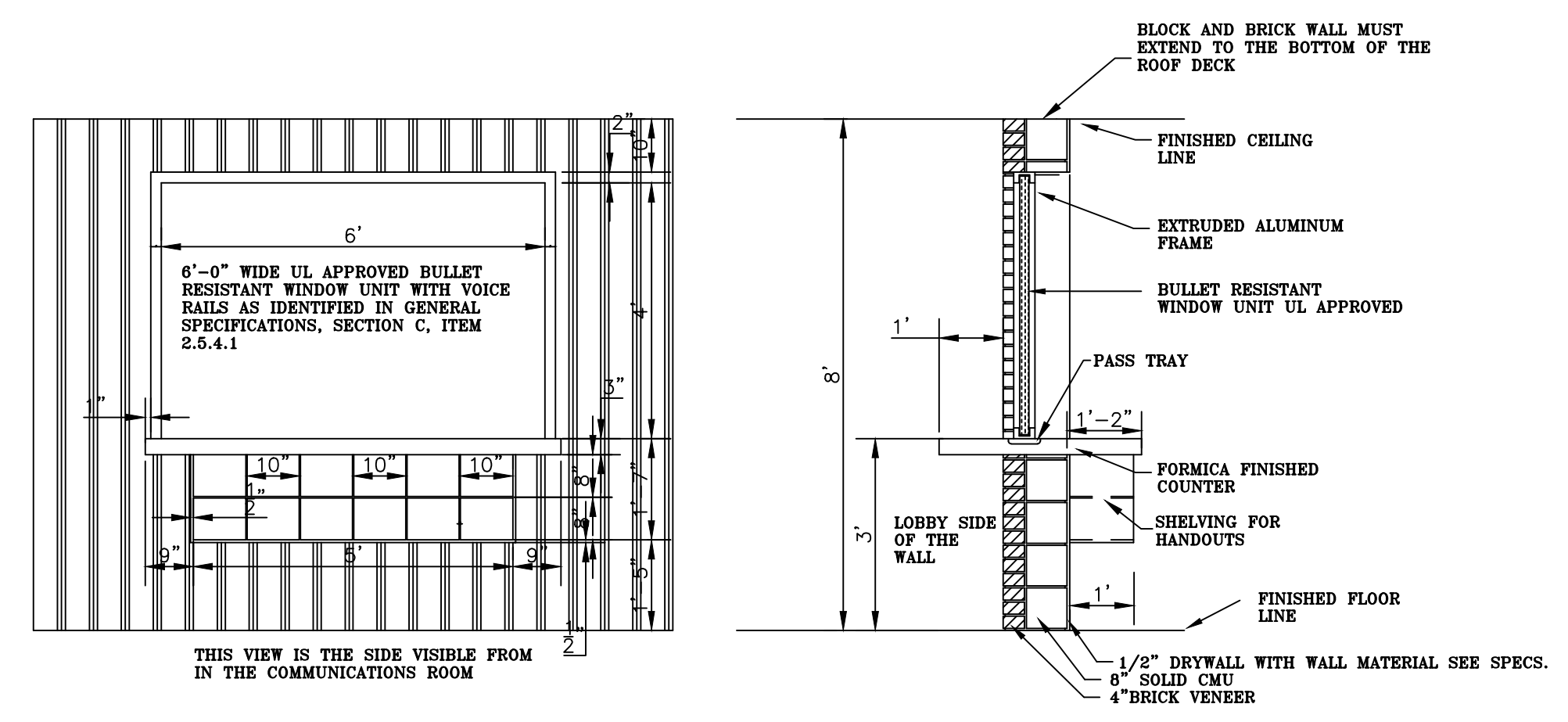

COMMUNICATIONS COUNTER

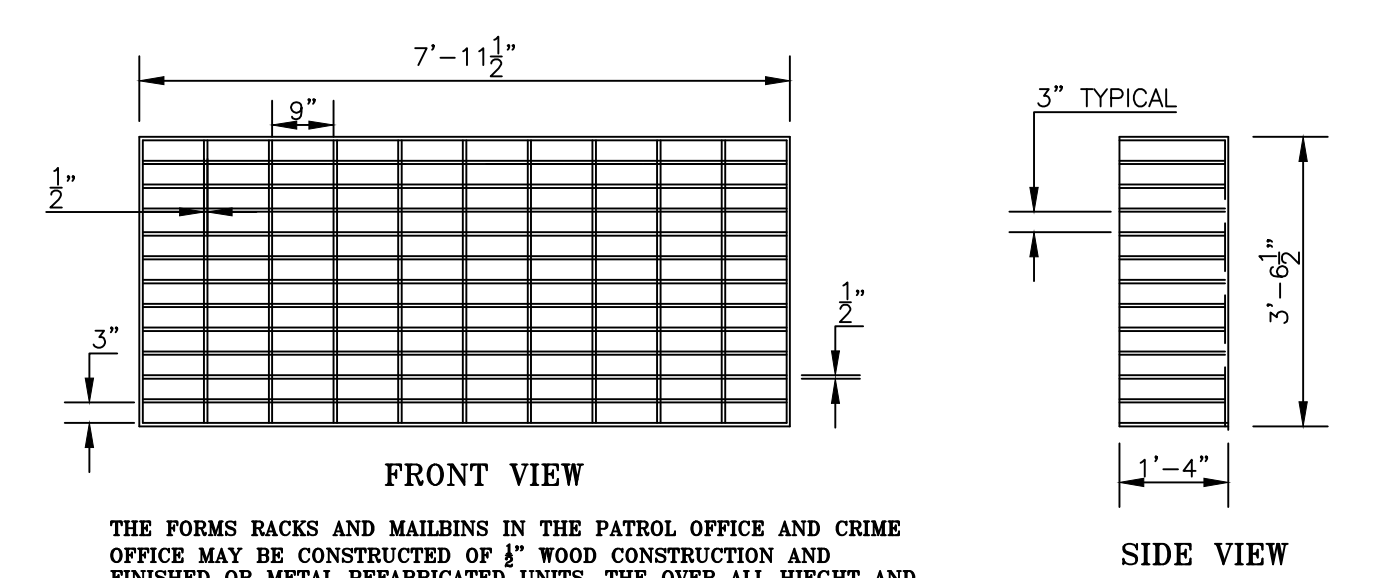

FORMS RACK & MAILBINS IN PATROL

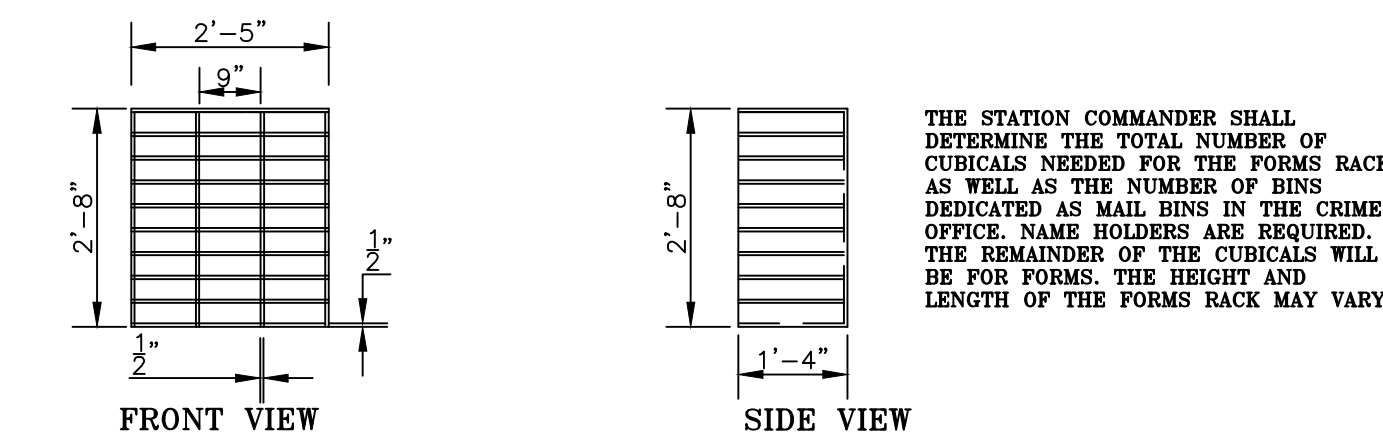

FORMS RACK / MAILBIN CRIME OFFICE

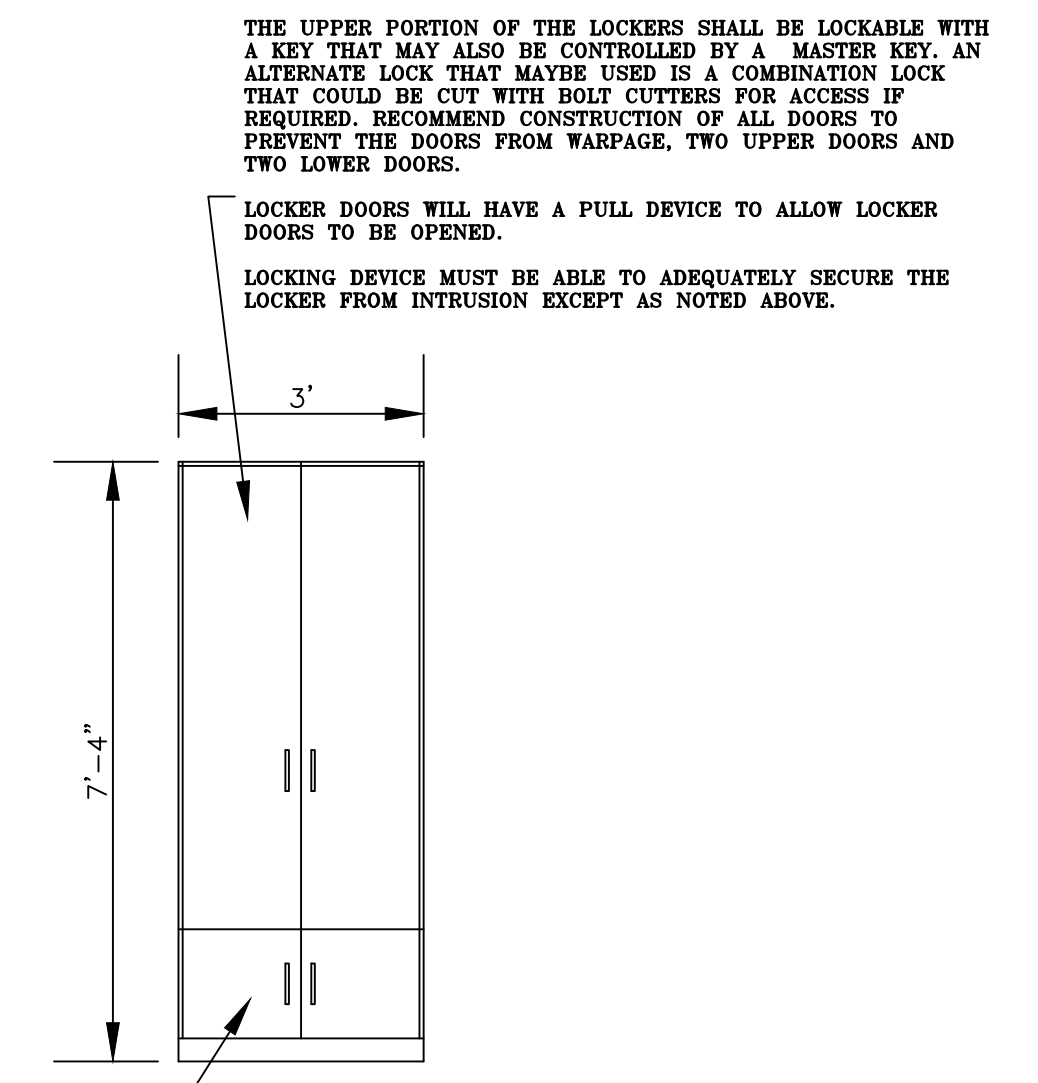

THE LOWER PORTION OF THE LOCKER SHALL HAVE IT'S OWN DOORS THAT WILL NOT BE LOCKABLE FOR STORAGE OF RIOT GEAR.

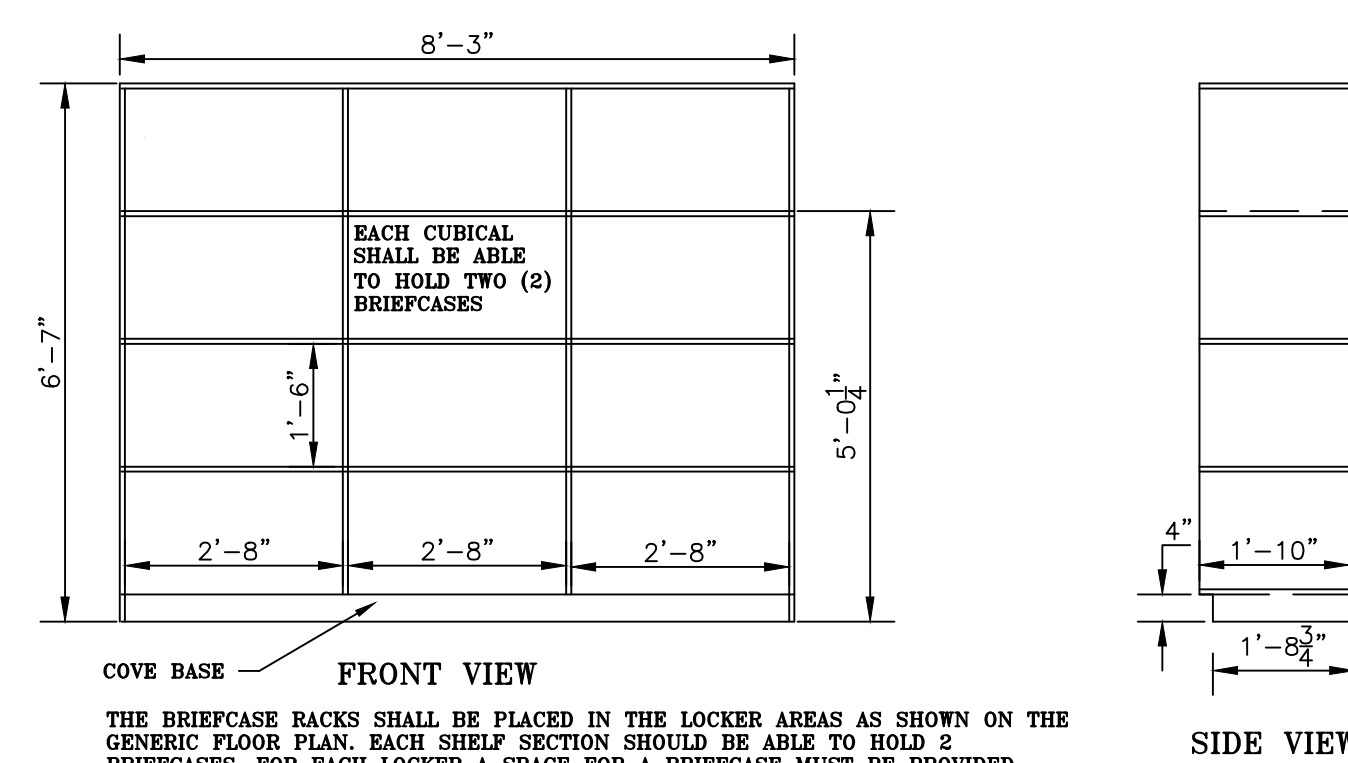

BRIEFCASE RACK DETAIL

THE BRIEFCASE RACKS SHALL BE PLACED IN THE LOCKER AREAS AS SHOWN ON THE GENERIC FLOOR PLAN. EACH SHELF SECTION SHOULD BE ABLE TO HOLD 2 BRIEFCASES. FOR EACH LOCKER A SPACE FOR A BRIEFCASE MUST BE PROVIDED. CONSTRUCTION MAY BE MADE IN SECTIONS AND CONNECTED ON SITE. THE CONSTRUCTION SHALL BE OF ADEQUATE STRENGTH TO SUPPORT THE WEIGHT. WHERE PLYWOOD IS USED IT SHALL BE GRADE \"A\" ON ALL VISIBLE SURFACES AND NOT LESS THAN GRADE \"B\" ELSEWHERE. THE SHELF SURFACE SHALL HAVE CARPET WITH METAL TRIM ON THE EDGE TO PREVENT THE CARPET FROM WEAR.

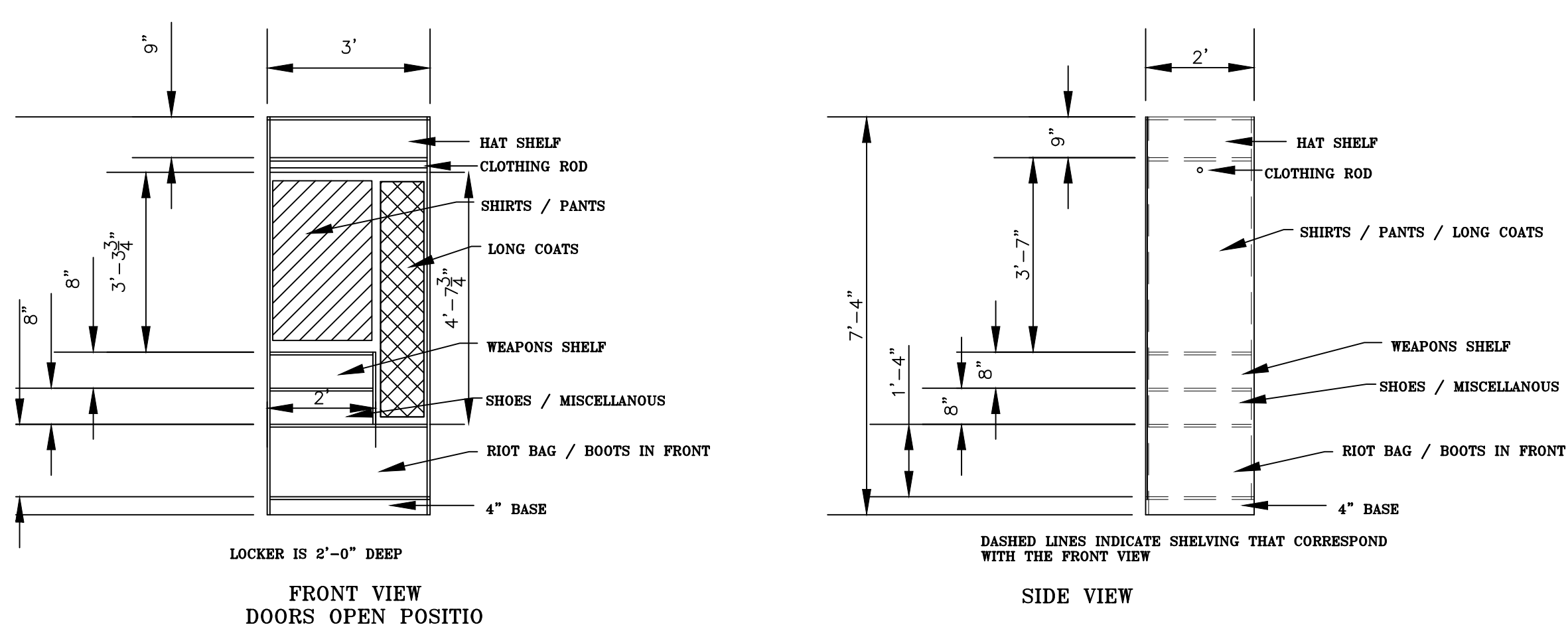

PROPOSED LOCKER

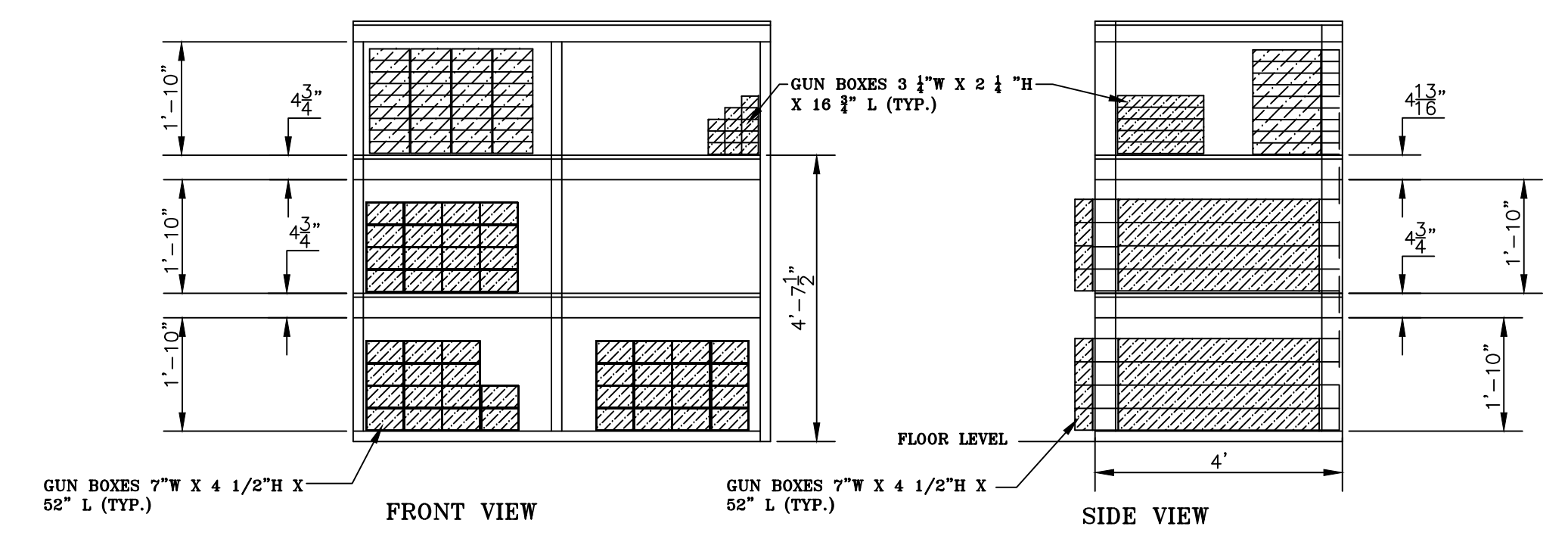

EVIDENCE ROOM CLOSET GUN STORAGE FRONT VIEW

THE GUN CLOSET IN THE EVIDENCE ROOM SHALL HAVE SHELVING FOR LONG GUNS TO BE PLACED IN EVIDENCE BOXES. THE BOXES ARE 52\"/>

General Notes
The construction of this facility shall meet the latest standards of AMERICANS with DISABILITIES ACT (ADA). Items contained on this drawing that do not comply with the requirements shall be the Lessors responsibility to install properly. The Lessor can obtain a copy of the (ADA) guidelines by calling (202) 272-5434 or on the internet at WWW.ACESS-BOARD. GOVIADAAGIHTMLIADAAGIHTM

No.	Revision/Issue	Date

Firm Name and Address
DETAIL SHEET

Project Name and Address
PENNSYLVANIA STATE POLICE NEW STATION

Project Sheet
 Date 4/25/09
 Scale NO SCALE
3

APPENDIX D

**COMMONWEALTH OF PENNSYLVANIA
REQUIREMENTS**

APPENDIX D

Commonwealth of Pennsylvania Specifications and Requirements Package

NORMAL HOURS:

Services, Utilities and Maintenance will be provided daily, 7 days a week, 24 hour access and use of the premises and lease amenities as necessary.

The Commonwealth shall have access to the leased space at all times, including, but not limited to, the use of elevators, toilets, lights and operation of business machines without additional payment.

PARKING REQUIRED:

The minimum number of parking spaces must be included in your proposal . When the Local code requirement for parking to sq. ft. ratio of parking spaces available on site indicates that the Commonwealth is entitled to more spaces than the specified minimum, then those additional spaces shall at the Commonwealth option be added to the above stated minimum.

CODE AND/OR REGULATIONS CHANGES OR VIOLATIONS:

When changes occur in Local, State or Federal codes or regulations and the Lessor is required to take action or equipment services or utilities furnished and activities of other occupants are not free of Safety, Health or Fire hazards the Lessor shall promptly take action to comply with code or regulation requirements at his sole expense.

LANDSCAPE MAINTENANCE:

Landscape maintenance is to be performed during the growing season on a weekly cycle and will consist of the following:

Watering, mowing and policing area to keep it free of debris.

Pruning and fertilization are to be done on an as needed basis. In addition, dead or dying plants are to be replaced.

SECURITY:

The Lessor shall provide security comparable to the types of protection given similar enterprises to prevent illegal entry or loitering in the space leased and to prevent unauthorized entry during off-duty hours.

MORE OR LESS USABLE AREA:

The Commonwealth shall receive any useable area within the leased premises in excess of that requested free of any and all costs or charges.

In the event there is less space than that requested the Commonwealth shall pay only for the useable area provided and/or shall have the option to exercise its rights under the lease if it deems, in its sole judgment, that the amount of space being provided is insufficient to meet its needs.

ADJUSTMENT FOR VACANT SPACE:

If the Commonwealth fails to occupy any portion of the leased premises or vacates the premises in whole or in part prior to expiration of the firm term of the lease, the rental rate shall be reduced as follows:

The rate shall be reduced by that portion of the costs per square foot of operating expenses not required to maintain the space. Said reduction shall occur after the Commonwealth gives 30 days prior notice to the Lessor, and shall continue in effect until the Commonwealth occupies the premises or the lease expires or is terminated.

Exercise of this right by the Commonwealth shall not preclude it from any other options or rights it may have under the lease.

